

Precision Planetary Gearboxes PS / RS Series

Overview

Description

The Helical Planetary Gearboxes incorporate design enhancements to provide superior performance for the most demanding high performance applications. The PS / RS gearboxes incorporate dual angular contact bearings providing higher radial load capacities while maintaining high input speeds. The design enhancements comprise among others, needle bearings to ensure a longer lifetime. Internal design changes and optimized gearing geometries provide the basis for the universal mounting position.

Common mounting kits across multiple gear head lines promote quicker deliveries and ease of mounting to any servo motor.

Mounting to any servo motor is as easy as A-B-C (adapter, bushing, collet).



Features

- **Higher radial load capacity:**
Angular contact output bearings
- **Increased service life:**
Needle bearings
- **Life time lubrication**
- **Universal Mounting Kits:**
Quicker deliveries and easier mounting
- **High nominal torque and low backlash:**
Helical planetary gearing
- **High stiffness:** Integrated planetary gear head
- **High wear resistance:**
Plasma Nitriding heat treating

Technical Characteristics - Overview

Series	Unit	PS	RS
Gear geometry		Helical Planetary	Helical Planetary/ Spur Bevel
Type		In-Line	Right Angle
Frame sizes	[mm]	60...115	
Maximum input speed	[min ⁻¹]	up to 6000	
Nominal torque	[Nm]	27...230	13...220
Radial force	[N]	>7500	
Life	[h]	20 000	
Backlash	[arcmin]	up to <3	up to <4

PS Series: In - Line Gearboxes

Technical Characteristics

Parameter	Unit	Ratio ⁽⁸⁾	PS60	PS90	PS115
Nominal output torque ⁽¹⁾ $T_{nom r}$	[Nm]	3 , 15, 30	27	76	172
		4, 5 , 7, 20 , 25, 40, 50 , 70	37	110	230
		10 , 100	32	93	205
Maximum acceleration torque $T_{acc r}$	[Nm]	3 , 15, 30	34	105	225
		4, 5 , 7, 20 , 25, 40, 50 , 70	48	123	285
		10 , 100	37	112	240
Emergency stop output torque ⁽²⁾ $T_{em r}$	[Nm]	3 , 15, 30	80	260	600
		4, 5 , 7, 20 , 25, 40, 50 , 70	70	230	500
		10 , 100	60	200	430
Nominal drive speed $N_{nom r}$	[min ⁻¹]	3	3000	2500	2000
		4, 5	3500	3000	2500
		7, 10 , 15	4000	3500	3000
		20 , 25, 30	4500	4000	3500
		40, 50	4800	4400	3800
		70, 100	5200	4800	4200
Maximum input speed $N_{max r}$ ⁽³⁾	[min ⁻¹]	3...100	6000	5500	4500
Maximum radial force Pr_{max} ⁽⁴⁾	[N]		1650	4800	7500
Maximum axial load Pa_{max} ⁽⁵⁾	[N]		2100	3600	6800
Life	[h]		20 000 (lifetime lubrication)		
Backlash - standard ⁽⁶⁾	[arcmin]	3...10 (1 step)	<6	<6	<4
		15...100 (2 step)	<8	<8	<6
Backlash - reduced ⁽⁶⁾	[arcmin]	3...10 (1 step)	<4	<4	<3
		15...100 (2 step)	<6	<6	<5
Efficiency at nominal torque	%	3...10	97	97	97
		15...100	94	94	94
Noise level at 3000 min⁻¹ ⁽⁷⁾	[db]	3...100	<62	<62	<65
Torsional rigidity	[Nm/arcmin]	3...100	3	12	27
Operating temperature	[°C]	3...100	-20...90		
Lubrication		3...100	per maintenance schedule		
Orientation		3...100	any		
Direction of Rotation		3...100	same as input		
Enclosure rating			IP65		
Rotor inertia			see page 222		
Weight	[kg]	3...10	1.3	3.0	7.0
		15...100	1.7	5.0	10.0

⁽¹⁾ At nominal speed $N_{nom r}$.

⁽²⁾ Maximum of 1000 stops.

⁽³⁾ Cycle mode.

⁽⁴⁾ Max. radial load applied to the center of the shaft at 100 min⁻¹

⁽⁵⁾ Max. axial load at 100 min⁻¹.

⁽⁶⁾ Measured at 2 % of rated torque.

⁽⁷⁾ Measure at 1 m.

⁽⁸⁾ Gearboxes in bold print - ratios with standard reversing play are on stock.

Load on Input Shaft

PS60

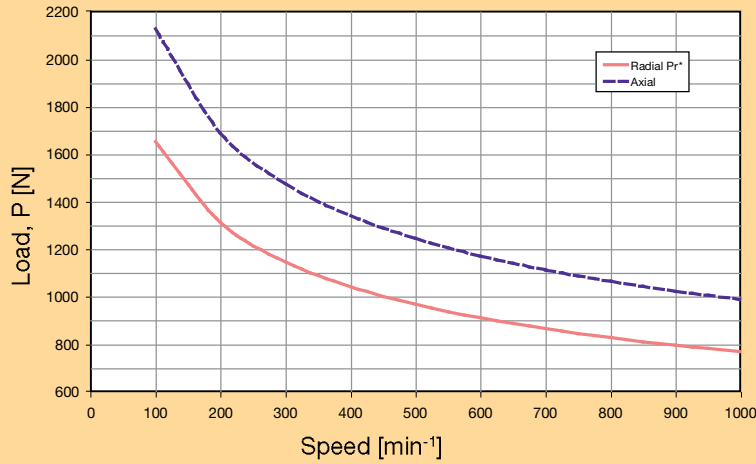

Formulas to calculate radial load (P_{rx}) at any distance "X" from the gearbox mounting surface:

$$P_{rx} = P_r * 75 \text{ mm} / (49 \text{ mm} + X)$$

PS90

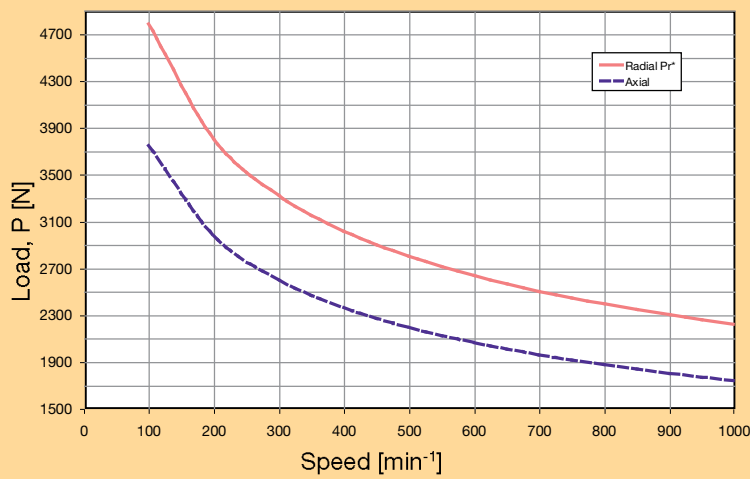

$$P_{rx} = P_r * 96 \text{ mm} / (62 \text{ mm} + X)$$

PS115

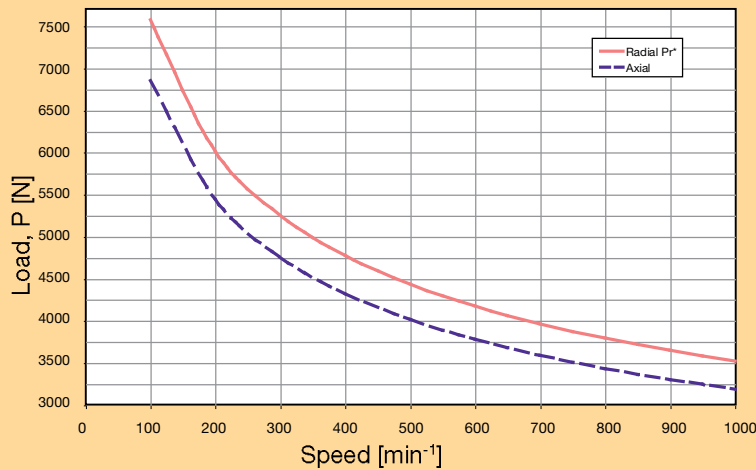

$$P_{rx} = P_r * 124 \text{ mm} / (81 \text{ mm} + X)$$

* Radial load applied to center of the shaft.

Dimensions

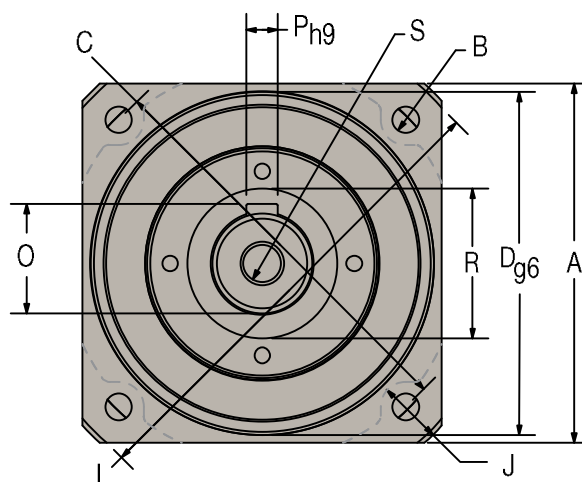
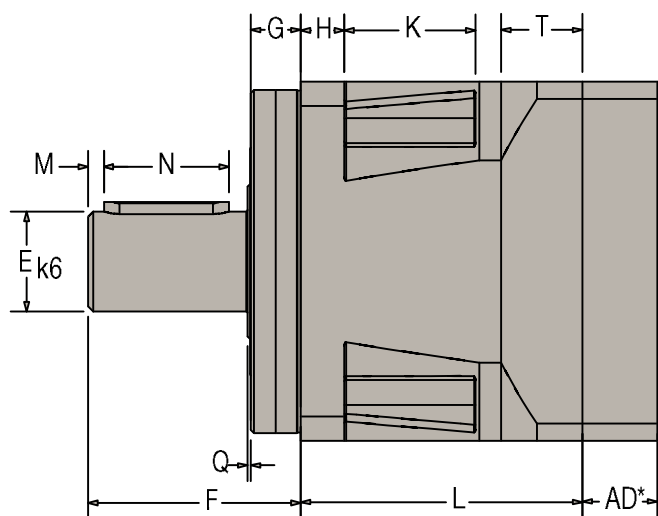

AD*: see table "Universal Mounting Kits"

Frame size	All dimensions in mm	PS60	PS90	PS115
A	Flange cross section	62	90	115
B	Fixing bore	5.5	6.5	8.5
C	Bolt circle	70	100	130
D	Motor pilot Ø	50	80	110
E	Drive shaft Ø	16	22	32
F	Drive shaft length	40	52	68
G	Motor pilot depth	11	15	16
H	Flange width	8	10	14
I	Ø Housing	80	116	152
J	Housing recess	5	6.5	7.5
K	Recess length	24	33	42
L1	Length single stage	59.8	69.5	90.2
L2	Length double stage	94.8	113	143.4
M	Distance from shaft end	2	3	5
N	Keyway length	25	32	40
O	Key height	18	24.5	35
P	Keyway width	5	6	10
Q	Collar height	1	1	1.5
R	Collar Ø	22	35	50
S	Center bore (shaft end)	M5x8	M8x16	M12x25
T	Width of flange on output side	20.5	20	26

Universal Mounting Kits

Adapter length "AD" dimension

Frame size	Motor shaft length [mm]	Gearbox adapter length [mm]
60	16...35	16.5
	35.1...41	22.5
90	20...40	20
	40.1...48	28.5
115	22...50	24
	50.1...61	35

PS: Rotor Inertia

All rotor inertias refer to the gearbox input

Ratio	Unit	PS60	PS90	PS115
3	[kgmm ²]	25	97	340
4	[kgmm ²]	17	67	220
5	[kgmm ²]	15	51	170
7	[kgmm ²]	14	41	130
10	[kgmm ²]	14	37	110
15	[kgmm ²]	15	52	170
20	[kgmm ²]	15	51	170
25	[kgmm ²]	15	51	170
30, 40, 50, 70, 100	[kgmm ²]	13	37	110

RS Series: Right - Angle Gearboxes

Technical Characteristics

Parameter	Unit	Ratio	RS60	RS90	RS115
Nominal output torque ⁽¹⁾ $T_{nom r}$	[Nm]	5	13	55	85
		10	24	80	160
		15, 20, 25, 50	35	88	220
		30, 40, 100	30	86	195
Maximum acceleration torque $T_{acc r}$	[Nm]	5	19	83	127
		10	36	120	240
		15, 20, 25, 50	45	123	255
		30, 40, 100	37	112	240
Emergency stop output torque ⁽²⁾ $T_{em r}$	[Nm]	5	40	150	270
		10	72	240	480
		15, 20, 25, 50	80	250	510
		30, 40, 100	60	200	430
Nominal drive speed $N_{nom r}$	[min ⁻¹]	5, 10	3200	2800	2400
		15, 20, 25, 30, 40	3700	3300	2900
		50, 100	4200	3800	3400
Maximum input speed $N_{max r}$ ⁽³⁾	[min ⁻¹]	5...100	6000	5300	4500
Maximum radial force $P_{r max}$ ⁽⁴⁾	[N]		1650	4800	7500
Maximum axial load $P_{a max}$ ⁽⁵⁾	[N]		2100	3600	6800
Life	[h]		20 000 (lifetime lubrication)		
Backlash - standard ⁽⁶⁾	[arcmin]	5...10 (1 step)	<14	<12	<12
		15...100 (2 step)	<12	<10	<10
Backlash - reduced ⁽⁶⁾	[arcmin]	5...10 (1 step)	<10	<8	<8
		15...100 (2 step)	<8	<6	<6
Efficiency at nominal torque	%	5...10	94	94	94
Noise level at 3000 min⁻¹ ⁽⁷⁾	[db]	5...100	<65	<68	<68
Torsional rigidity	[Nm/arcmin]	5...100	2.5	10	22
Operating temperature	[°C]	5...100	-20...90		
Lubrication		5...100	per maintenance schedule		
Orientation		5...100	any, details see ordering information		
Direction of Rotation		3...100	Direction turns		
Enclosure rating			IP65		
Rotor inertia			see page 225		
Weight	[kg]	5...10	2.0	6.0	11.0

⁽¹⁾ At nominal speed $N_{nom r}$.

⁽²⁾ Maximum of 1000 stops.

⁽³⁾ Cycle mode.

⁽⁴⁾ Max. radial load applied to the center of the shaft at 100 min⁻¹

⁽⁵⁾ Max. axial load at 100 min⁻¹.

⁽⁶⁾ Measured at 2 % of rated torque.

⁽⁷⁾ Measure at 1 m.

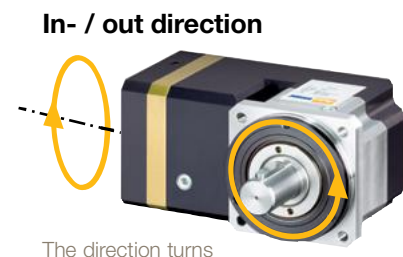

Load on Input shaft

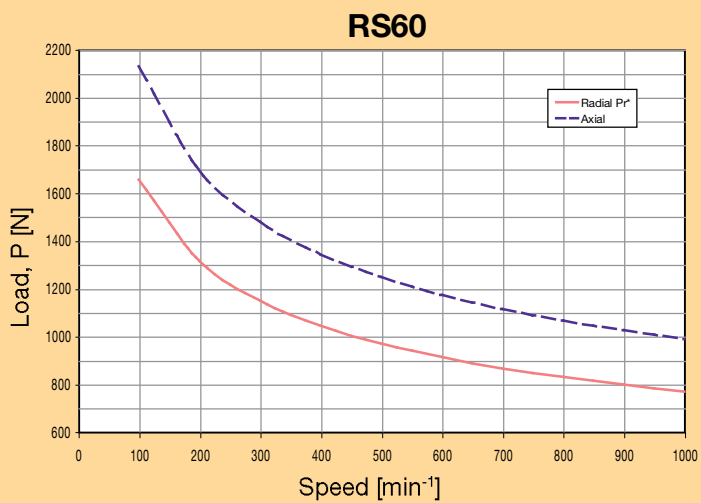

Formulas to calculate radial load (P_{rx}) at any distance "X" from the gearbox mounting surface:

$$P_{rx} = P_r * 75 \text{ mm} / (49 \text{ mm} + X)$$

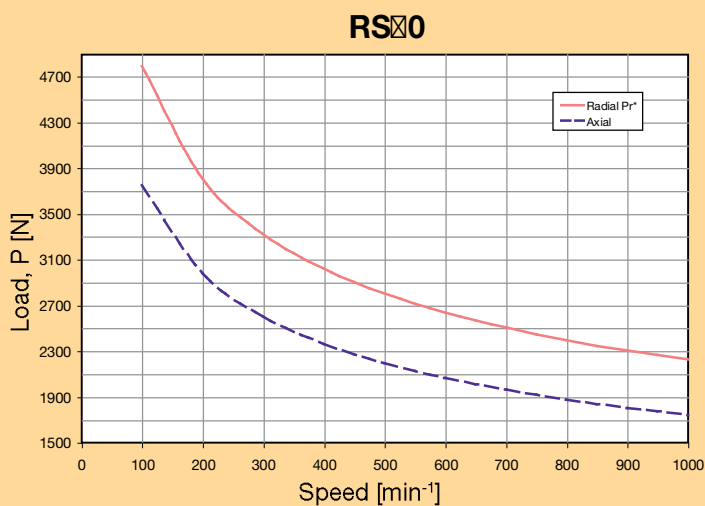

$$P_{rx} = P_r * 96 \text{ mm} / (62 \text{ mm} + X)$$

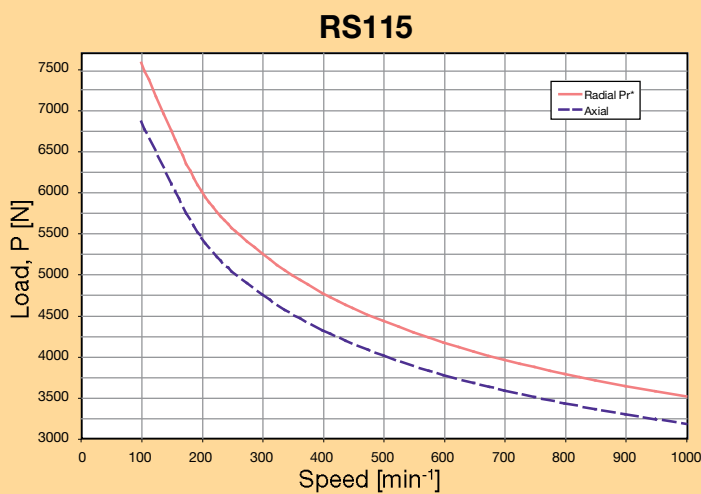

$$P_{rx} = P_r * 124 \text{ mm} / (81 \text{ mm} + X)$$

* Radial load applied to center of the shaft.

Dimensions

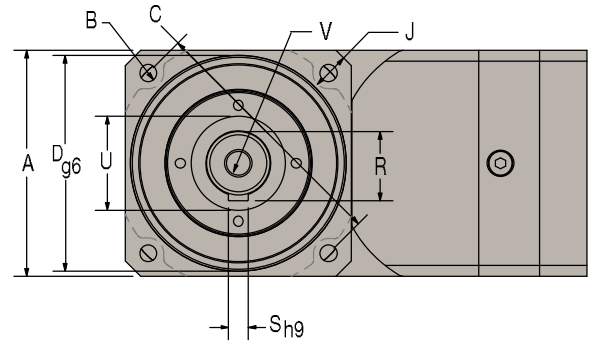
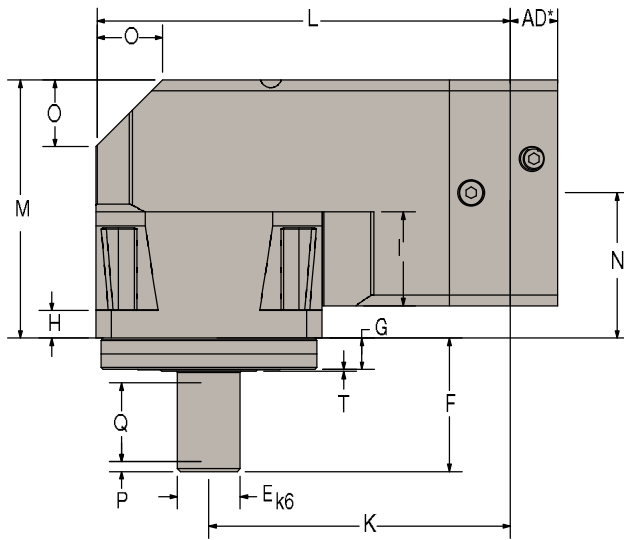

AD*: see table "Universal Mounting Kits"

Frame size	All dimensions in mm	RS60	RS90	RS115
A	Flange cross section	62	90	115
B	Mounting bore	5.5	6.5	8.5
C	Bolt circle	70	100	130
D	Motor pilot Ø	50	80	110
E	Input shaftØ	16	22	32
F	Length of input shaft	40	52	68
G	Motor pilot depth	11	15	16
H	Flange width	8	10	14
I	Enclosure recess	23.5	40.5	47.5
J	Recess length	5	6.5	7.5
K	Distance to output centerline	93.7	132	153.5
L	Housing length	124.7	177	211
M	Housing width	76.8	103	132
N	Distance to input centerline	47	58	74
O	Bevel height	14	25	32
P	Distance from shaft end	2	3	5
Q	Keyway length	25	32	40
R	Key height	18	24.5	35
S	Keyway width	5	6	10
T	Collar height	0.5	0.5	1
U	Collar Ø	22	35	45
V	Center bore (shaft end)	M5x8	M8x16	M12x25

Universal Mounting Kits

Adapter length "AD" dimension

Frame size	Motor shaft length [mm]	Gearbox adapter length [mm]
60	16...35	16.5
	35.1...41	22.5
90	20...40	20
	40.1...48	28.5
115	22...50	24
	50.1...61	35

RS: Rotor Inertia

All rotor inertias refer to the gearbox input

Ratio	Unit	RS60	RS90	RS115
5	[kgmm ²]	22	81	250
10	[kgmm ²]	19	61	190
15	[kgmm ²]	18	60	170
20	[kgmm ²]	17	51	140
25	[kgmm ²]	16	42	130
30	[kgmm ²]	18	60	170
40	[kgmm ²]	17	51	140
50	[kgmm ²]	15	40	110
100	[kgmm ²]	15	40	110

Adapter Flange / Motor - Dimensions (Gear Unit Input Side)

Dimensions [mm]

Motor ⁽¹⁾	Flange Type	Motor flange	Flange depth	Bolt circle Ø	Bore Ø	Pilot Ø	Pilot depth	Shaft Ø	Shaft length	Adapter flange		
		QF	PC	F	DF	C	S	D	L	Order No.	Fastening thread	AD ⁽²⁾ (short)
SM_60,###,##,5,11,S	B5	70	7	75	6	60	2.5	11	23	MU60-001	M5	16.5
M_70,###,##,5,11,S	B5	70	7	75	6	60	2.5	11	23	MU60-001	M5	16.5
NX3		56	8.5	75	5.5	60	2.5	11	23	MU60-001	M5	16.5
M_56,###,##,5,9,S	B5	56	6.5	63	5.5	40	2.5	9	20	MU60-003	M5	16.5
SM_60,###,##,8,9,S	B5	60	7	63	5.5	40	2.5	9	20	MU60-003	M5	16.5
SY56#	Nema23	56.5	4.83	66.67	5.3	38.1	1.6	6.35	25.4	MU60-005	M5	16.5
M_56,###,##,5,11,S	B5	56	6.5	63	5.5	40	2.5	11	23	MU60-254	M5	16.5
NX2		56	7.2-18	63	5.5	40	2.5	11	25	MU60-254	M5	16.5
NX1		42.5	6	50	3.2	30	2.5	9	25	MU60-255	M3	16.5
SM_82,###,##,8,14,S	B8	82	10	100	6.5	80	3.5	14	30	MU60-321	M6	16.5
SM_82,###,##,8,14,S	B8	82	10	100	6.5	80	3.5	14	30	MU90-001	M6	20
SM_82,###,##,8,19,S	B8	82	10	100	6.5	80	3.5	19	40	MU90-085	M6	20
NX4		91.5	10.5	100	7	80	3	19	40	MU90-085	M6	20
M_105,###,##,5,19,S	B5	105	10	115	9.5	95	3.5	19	40	MU90-088	M9	20
SM_100,###,##,5,19,S	B5	100	10	115	9	95	3.5	19	40	MU90-088	M8	20
SM_115,###,##,8,19,S	B8	115	10	130	9	95	3.5	19	40	MU90-345	M8	20
M_105,###,##,5,24,S	B5	105	10	115	9.5	95	3.5	24	50	MU115-005	M8	24
SM_100,###,##,5,24,S	B5	100	10	115	9	95	3.5	24	50	MU115-005	M8	24
SM_115,###,##,8,19,S	B8	115	10	130	9	95	3.5	19	40	MU115-006	M8	24
M_105,###,##,6,24,S	B6	105	10	130	9	110	3.5	24	50	MU115-010	M8	24
SM_115,###,##,7,24,S	B7	130	10	130	9	110	3.5	24	50	MU115-010	M8	24
NX6		121	10.5	130	9	110	3.5	24	50	MU115-010	M8	24
SM_82,###,##,8,14,S	B8	82	10	100	6.5	80	3.5	14	30	MU115-015	M6	24
SM_115,###,##,5,24,S	B5	145	10	165	11	130	3.5	24	50	MU115-026	M10	24
SM_142,###,##,5,24,S	B5	145	10	165	11	130	3.5	24	50	MU115-026	M10	24
SM_82,###,##,5,19,S	B5	100	10	115	9	95	3.5	19	40	MU115-039	M8	24
SM_100,###,##,5,19,S	B5	100	10	115	9	95	3.5	19	40	MU115-039	M8	24
SM_82,###,##,8,19,S	B8	82	10	100	6.5	80	3.5	19	40	MU115-089	M6	24
SM_115,###,##,8,24,S	B8	115	10	130	9	95	3.5	24	50	MU115-257	M8	24
M_105,###,##,9,24,S	B9	96	10	100	7	80	3.5	24	50	MU115-269	M6	24

- ⁽¹⁾ MB/SMB: for drives TPDM, SLVDN, TwinN, SPDN, HiDrive
MH/SMH: for drive Compax3
- ⁽²⁾ AD: Adapter length (please refer to the "dimensions" chapter)

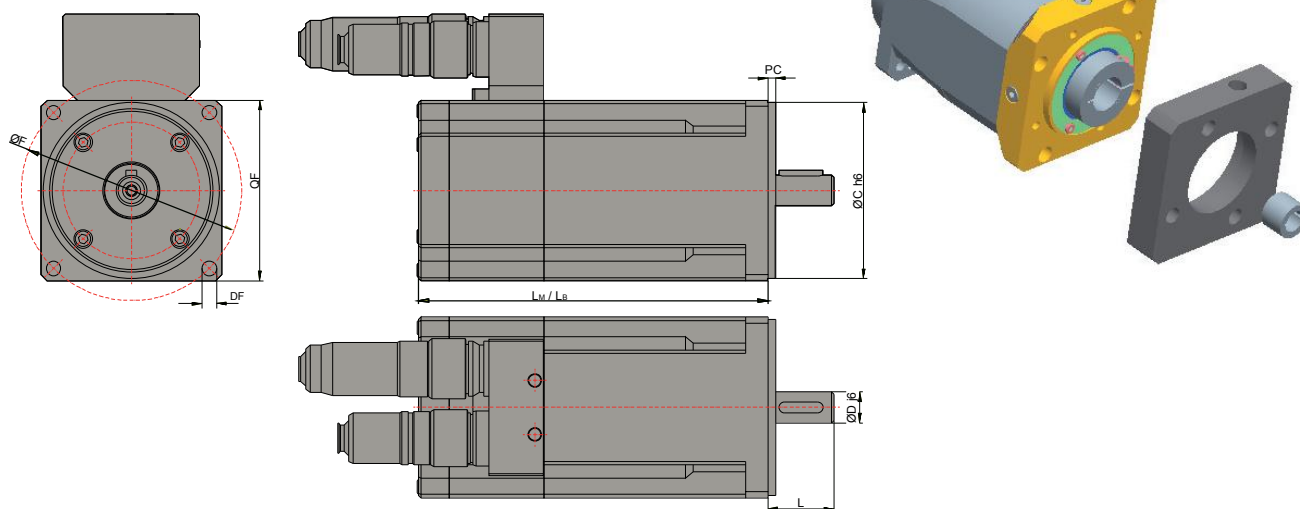

Gearbox Sizing

Parker has prepared the following procedure to provide a quick method for selecting a gearbox.

1) Application parameters:

- Acceleration time (t_{acc})
- Continuous run time (t_{cont})
- Deceleration time (t_{dec})
- Dwell time (t_{dwell})
- Acceleration torque (T_{acc})
- Continuous torque (T_{cont})
- Deceleration torque (T_{dec})

- Application speed (N_{cont})
- Transmission ratio (i)
- Gearbox nominal torque ($T_{nom r}$)
- Max. permissible acceleration torque ($T_{acc r}$)
- Percentage of acceleration torque vs. continuous cycle time (t_{total})
- Max. input speed ($N_{max r}$)

2) Duty cycle:

$$\text{Duty cycle} = t_{acc} + t_{cont} + t_{dec} / t_{total} \times 100 \%$$

If duty cycle is <60 % and ($t_{acc} + t_{cont} + t_{dec}$) is less than 20 minutes, the motion is considered to be intermittent.

If duty cycle is <60 % and ($t_{acc} + t_{cont} + t_{dec}$) is more than 20 minutes, the motion is considered to be continuous.

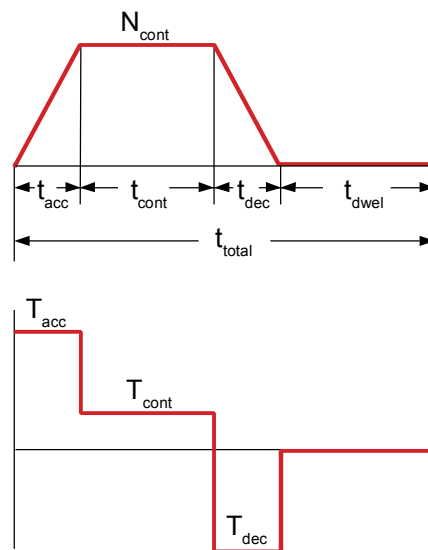

3) For Cycle mode applies:

Determine T_{acc} % of ($T_{acc} + T_{cont} + T_{dec}$):
 $T_{acc} / (T_{acc} + T_{cont} + T_{dec}) \times 100\%$

Define the ratio: T_{cont} / T_{acc}

Use the table to select the load factor K.

Compare Accel/Decel torque to the maximum permissible accel torque of the gearbox $T_{acc r}$: $T_{acc} < T_{acc r} \times K$, if not, please select a more suitable gearbox.

Compare the required maximum speed to the maximum rated speed of the gearbox.
 $N_{max} < N_{max r / i}$ (i-gearbox ratio)

Table: Load Factor K

T_{acc} %	$0 < T_{cont} / T_{acc} < 0.25$	$0.25 < T_{cont} / T_{acc} < 0.5$
10-15	1.0	1.0
15-20	1.0	0.95
20-25	0.94	0.89
25-30	0.88	0.84
30-35	0.81	0.79
35-40	0.76	0.75
40-45	0.71	0.70
45-50	0.66	0.66

4) For continuous operation applies:

$$T_{nom} < T_{nom r}$$

$$N_{nom} < N_{nom r} / i$$

5) Check the Emergency Stop Torque Rating.

6) Verify Radial and Axial Shaft Load of the Application for the selected Gearbox.

Order Code

PS / RS Gearboxes

	1	2		3		4	5		6
Order example	PS	60	-	003	-	S	2	/	MU60-088

1 Gearbox type

- **PS** Gearbox for in-line mounting
- **RS** Right-angle gearboxes

2

- **60** Flange 60
- **90** Flange 90
- **115** Flange 1150

3 Ratio

	i	PS	RS
003	3	● x	
004	4	x	
005	5	● x	x
007	7	x	
010	10	● x	x
015	15	x	x
020	20	● x	x
025	25	x	x
030	30	x	x
040	40	x	x
050	50	● x	x
070	70	x	
100	100	x	x

4 Reverse play / orientation

- **S** Standard
- **L** Reduced

5 Series

- **2** Gen 2 Gearboxes

- **On stock, short delivery times**

6 Adapter flange / Motor assignment (Dimensions see next page)

- **MU60-001** SMH60,###,##,5,11,S
MH70,###,##,5,11,S
NX3
- **MU60-003** MH56,###,##,5,9,S
SMH60,###,##,8,9,S
- **MU60-005** SY56
- **MU60-254** MH56,###,##,5,11,S
NX2
- **MU60-255** NX1
- **MU60-321** SMH,###,###,8,14,S
- **MU90-001** SMH82,###,##,8,14,S
- **MU90-085** SMH82,###,##,8,19,S
NX4
- **MU90-088** MH105,###,##,5,19,S
SMH100,###,##,5,19,S
- **MU90-345** SMH115,###,##,8,19,S
- **MU115-005** MH105,###,##,5,24,S
SMH100,###,##,5,24,S
- **MU115-006** SMH115,###,##,8,19,S
- **MU115-010** MH105,###,##,6,24,S
SMH115,###,##,7,24,S
NX6
- **MU115-015** SMH82,###,##,8,14,S
- **MU115-026** SMH115,###,##,5,24,S
SMH142,###,##,5,24,S
- **MU115-039** SMH82,###,##,5,19,S
SMH100,###,##,5,19,S
- **MU115-089** SMH82,###,##,8,19,S
- **MU115-257** SMH115,###,##,8,24,S
- **MU115-269** MH105,###,##,9,24,S
- **MUxxx-yyy** Additional motors: Selection of the adapter flange on www.parker-eme.com/gear_kits