



aerospace
climate control
electromechanical
filtration
fluid & gas handling
hydraulics
pneumatics
process control
sealing & shielding



SensoControl®

Diagnostic Test Equipment for Hydraulics



ENGINEERING YOUR SUCCESS.

All the instruments meet the guidelines of the European Community (EU).
It is confirmed that these products are approved acc. to following standards.



DIN/EN 61000-6-2
DIN/EN 61000-6-3

Note!

This document and other information from Parker Hannifin GmbH, provide product or system options for further investigation by users having technical expertise. Before you select or use any product or system it is important that you analyse all aspects of your application and review the information concerning the product or system in the current product catalogue. Due to the variety of operating conditions and applications for these products or systems, the user, through his own analysis and testing, is solely responsible for making the final selection of the products and systems and assuring that all performance and safety requirements of the application are met. The products are subject to change by Parker Hannifin GmbH at any time without notice.



Technical subject to change. March 2010.

© Copyright 2010, Parker Hannifin Corporation. All Rights Reserved.

Table of Contents



		Page
	Index	4
	Product Overview	5
Measurement and Display		6-15
1	ServiceJunior	8-11
2	Serviceman	12-15
Measurement, Display and Storage		16-29
3	ServiceJunior <i>wireless</i>	16-20
4	The Parker Service Master <i>Easy</i>	21-25
5	The Parker Service Master <i>Plus</i>	26-31
6	Software SensoWin®	32-33
7	Electrical Signal Measurement	34-35
Pressure/Temperature/RPM Measurement		36-49
8	SCPT Pressure/Temperature Sensors	38-40
9	SCPT-CAN Pressure/Temperature Sensors	41-42
10	SCT Temperature Sensors	43-46
11	SCPRM Tachometer	47-49
Volume Flow Measurement		50-68
12	Turbine Flow Meter SCFT	52-55
13	Turbine Flow Meter SCFT-CAN	56-59
14	Hydraulic Tester SCLV	60-63
15	Flow Meter SCQ	64-68
Accessories		69-72
16	SCK Connection Cable	69-70
17	SCA Adapter	71-72
SCKIT and Calibration Service		73-78
18	Equipment Case and SCKIT	73-76
19	Calibration Service	77-78

Index - Order Code



K-SCFT-xxx-02-02	77	SCA-EMA-3/1	71	SCLV-PTQ-300	60
K-SCFT-xxx-C2-05	77	SCA-EMA-3/2	71	SCLV-PTQ-300-C2-05	60
		SCA-EMA-3/3	71	SCLV-PTQ-750	63
K-SCJN-KIT-xxx	77	SCA-EMA-3/4	71		
K-SCJN-xxx-01	77	SCA-EMA-3/PQC	72	SCM-152-0-02	12
K-SCJNP-KIT-xxx-RC	77	SCA-GMA3/20S/T	46	SCM-152-1-02	12
K-SCJNP-xxx-01-RC	77			SCM-152-2-02	12
		SCAQ-060	67	SCM-330-2-02	24
K-SCKIT-152-0-00	77	SCAQ-150	67	SCM-340-2-02	24
K-SCKIT-152-0-600	77	SCAQ-GIR1/2A4CX	67	SCM-500-00-00	31
K-SCKIT-152-1-00	77			SCM-500-01-00	31
K-SCKIT-152-2-00	77	SCC-340	74	SCM-500-01-01	31
K-SCKIT-152-PQ	77	SCC-500	74		
K-SCKIT-330-00	77	SCC-DRV-300	74	SCMA-FCU-600	34
K-SCKIT-340-00	77			SCMA-VADC-600	34
K-SCKIT-340-PTQ	77	SCFT-150-DRV	63		
K-SCKIT-500-00-00	77	SCFT-150-DRV-C2-05	63	SCPT-xxx-02-02	40
K-SCKIT-500-01-00	77	SCFT-750-C2-05	59	SCPT-xxx-02-02-PQC	40
K-SCKIT-500-01-01	77	SCFT-xxx-02-02	55	SCPT-xxx-C2-05	42
		SCFT-xxx-C2-05	59	SCPT-xxx-C2-05-PQC	42
K-SCM-152-0-02	77				
K-SCM-152-1-02	77	SCJN-KIT-xxx	74	SCQ-060-0-02	67
K-SCM-152-2-02	77	SCJN-xxx-01	9,74	SCQ-150-0-02	67
K-SCM-330-2-02	77	SCJNA-PC	74	SCQ-M24X1.5-ED	67
K-SCM-340-2-02	77	SCJNP-KIT-xxx-RC	74	SCQ-M42X1.5-ED	67
K-SCM-500-00-00	77	SCJNP-xxx-01-RC	17,74	SCQ-R1/2-ED	67
K-SCM-500-01-00	77			SCQ-R3/4-ED	67
K-SCM-500-01-01	77	SCK-002-08	69	SCQ-xxx-0-02	51
		SCK-102-02-08	69		
K-SCPT-xxx-02-02	77	SCK-102-03-02	68	SCRPM-220	49
K-SCPT-xxx-02-02-PQC	77	SCK-102-05-02	68		
K-SCPT-xxx-C2-05	77	SCK-102-05-12	68	SCRPMA-001	49
K-SCPT-xxx-C2-05-PQC	77	SCK-315-02-34	24	SCRPMA-002	49
		SCK-318-05-21	24		
K-SCQ-xxx-0-02	77	SCK-401-0.3-Y	70	SCSN-450	24
		SCK-401-02-4F-4M	70		
K-SCRPM-220	77	SCK-401-05-4F-4M	70	SCT-150-0-02	46
		SCK-401-10-4F-4M	70	SCT-150-04-02	46
K-SCT-150-0-02	77	SCK-401-R	70	SCT-400-K-01	46
K-SCT-150-04-02	77			SCTA-400-02	46
		SCKIT-152-0-00	75		
SC-910	67	SCKIT-152-0-600	75	SMA3-1500	74
SC-911	67	SCKIT-152-1-00	75		
SC-912	67	SCKIT-152-2-00	75		
		SCKIT-152-PQ	75		
SC-BAT-340	24	SCKIT-330-00	75		
		SCKIT-340-00	75		
SCA-1/2-EMA-3	71	SCKIT-340-PTQ	75		
SCA-1/2-EMA-3-HP	71	SCKIT-500-00-00	76		
SCA-1/2-PQC	72	SCKIT-500-01-00	76		
SCA-1/4-EMA-3	71	SCKIT-500-01-01	76		
SCA-1/4-PQC	72				
SCA-90-EMA-3	71	SCLV-DISC-300	63		
		SCLV-DISC-800	63		



Product Overview

Measurement and Display:





ServiceJunior <ul style="list-style-type: none"> ✓ Rugged, reliable and simple to operate ✓ An outstanding price-performance ratio Page 8-11		Serviceman <ul style="list-style-type: none"> ✓ Rugged, reliable and simple to operate ✓ Automatic sensor recognition Page 12-15	
--	---	--	---

Measurement, Display and Storage:





ServiceJunior wireless <ul style="list-style-type: none"> ✓ Wireless recording of measured values ✓ Software JuniorWin® Page 16-20		The Parker Service Master Easy <ul style="list-style-type: none"> ✓ Automatic sensor recognition ✓ Up to 4 channels ✓ PC connection ✓ Software SensoWin® Page 21-25		The Parker Service Master Plus <ul style="list-style-type: none"> ✓ Portable multi-function hand-held measuring instrument with CAN bus connection ✓ Record, save and analyze measurements Page 26-31	
--	---	---	--	---	---

Software SensoWin® <ul style="list-style-type: none"> ✓ Automate measurement procedures, analyze and print-out documentation Page 32-33		Electrical Signal Measurement <ul style="list-style-type: none"> ✓ Frequency, current, voltage measurements ✓ e.g., for connecting external sensors Page 34-35	
--	---	--	---

Pressure/ Temperature/ RPM Measurement

SCPT Pressure/ Temperature Sensors  <ul style="list-style-type: none"> ✓ Pressure/Temperature sensors Page 38-40	SCPT-CAN Pressure/ Temperature Sensors  <ul style="list-style-type: none"> ✓ Pressure/Temperature sensors with CAN-Bus Page 41-42	SCT Temperature Sensors  <ul style="list-style-type: none"> ✓ High-pressure-resistant temperature probes Page 43-46	SCPRM Tachometer  <ul style="list-style-type: none"> ✓ No-contact speed measurements Page 47-49
--	---	--	---

Volume Flow Measurement

SCFT Turbine Flow Meter  <ul style="list-style-type: none"> ✓ Turbine flow meter Page 52-55	SCFT-CAN Turbine Flow Meter  <ul style="list-style-type: none"> ✓ CAN bus technology Page 56-59	SCLV Hydraulic Tester  <ul style="list-style-type: none"> ✓ Hydraulic tester Page 60-63	SCQ Flow Meter  <ul style="list-style-type: none"> ✓ Flow meter Page 64-68
---	---	--	--

Accessories, Equipment Cases and Calibration Services

SCK Connection Cable  <ul style="list-style-type: none"> ✓ Cable for CAN bus and analog sensors Page 69-70	SCA Diagnostic Adapter  <ul style="list-style-type: none"> ✓ Adapter to M16x2 measurement system Page 71-72	Equipment Case and SCKIT  Page 73-76	Calibration Service  Page 77-78
--	---	--	--

- Long-term stability
- Rugged design
- Easy operation
- Flexible use on site
- Documentation of measured values

SensoControl® handmeters and complete measuring systems are perfectly suitable measuring tools for every application. Whether they are used in the industrial area, in mobile hydraulics, for service or repair: measuring and processing of hydraulic values is the basis of safe trouble shooting. The systematic search for errors with modern aids is something the service engineer simply cannot do without.

High-speed processes, such as switching valves, cylinder strokes, pressure peaks, differential pressures and flow changes must be measured and evaluated simultaneously.



The **SensoControl®** handmeters have been specially developed for the following applications:

- Measurement and display of all hydraulic values, such as pressure, differential pressure, pressure peaks, temperature and flow, as well as speed.
- They are perfectly suitable for the mobile recording of measured values and feature high precision combined with easy operation.

All measuring devices as well as their accessories are manufactured and tested in our own plants. Our ever-increasing insistence on quality and flexibility make Parker a reliable partner.



Finding the Best Product

Choice/Features	Measurement and display		Measuring instruments with measured-value memory		
	ServiceJunior	Serviceman	ServiceJunior wireless	The Parker Service Master Easy	The Parker Service Master Plus
Measuring and read out					
Read out	ACT - MIN/MAX (Peak-Hold)	ACT - MIN/MAX	ACT - MIN/MAX (Peak-Hold)	ACT - MIN/MAX FS	ACT - MIN/MAX (Peak-Hold)
2 inputs	—	●	—	●	●
3 inputs	—	—	—	●	●
4 inputs	—	—	—	●	●
6 inputs	—	—	—	—	●
Additional inputs					●
Pressure peaks	10 ms	2 ms	10 ms	1 ms/0,25 ms	1 ms/0,1 ms
Pressure	●	●	●	●	●
Differential pressure (P1-P2)	—	●	—	●	●
Functions					
Rechargeable battery	battery	●	battery	●	●
Interface	—	○	USB	USB	USB/Ethernet
OnLine-Function		○	—	●	●
Data recording	—	—	●	●	●
External power supply	—	●	—	●	●
Connection sensors					
Pressure	●	●	●	●	●
Temperature/RPM/Flow	—	●	—	●	●
Electrical signals	—	○	—	○	●
Auxiliary sensors	—	○	—	○	●
Parker CAN bus sensors	—	—	—	—	●

- not available
- optional
- standard

- Digital pressure measurement and back-lit display
- Accuracy $\pm 0,5\%$ FS
- Display with bar graph (trailing indicator) with peak & hold function
- Pressure peaks captured – 10 ms scanning rate
- Easy operation
- Long-term stability
- Back-lit measured value display
- Pressure ports stainless steel 1/4" BSP



ServiceJunior Digital Pressure Gauge

The **ServiceJunior** makes possible the measurement and display of pressures with one instrument. Measured values are shown with high precision on a 4-digit display. Pressure peaks are securely captured at a scanning rate of 10 ms.



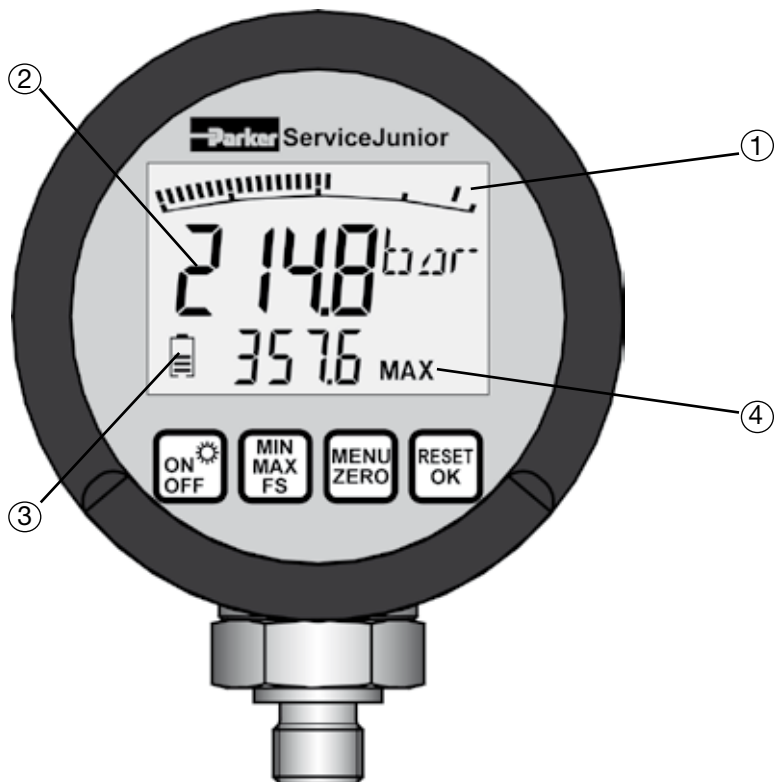

The **ServiceJunior** is distinctive through its very simple operation. With its convincing price to power ratio, the instrument offers all the advantages of digital pressure measurement.





- ① Trailing-indicator display with bar-graph due to peak & hold function
- ② Actual value back-lit display (15 mm)
- ③ Battery level display
- ④ Display of MIN/MAX or Full Scale Range display (FS)

Menu functions

-  On/off switch
Back-lit display
-  Minimum/maximum value/
FullScale
-  Menu: auto shut-off
Choice of units
Zero: Zero point correction
-  Delete MIN/MAX value
Confirm menu function

ServiceJunior:	
ServiceJunior: Range: -1...016 bar/0...100 bar/0...400 bar/0...600 bar/0...1.000 bar	SCJN-xxx-01
1 ServiceJunior (acc. to pressure range) 2 batteries 1,5 V alkaline 1 adapter SCA-1/4-EMA-3	

See page 77 for kits and equipment cases.



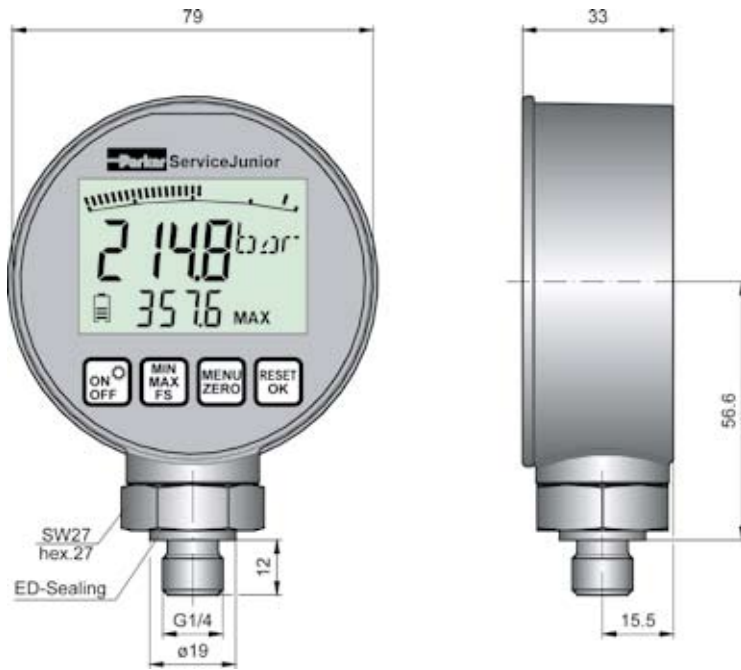

Technical Data					
SCJN	016	100	400	600	1000
Range (bar)	-1...16	0...100	0...400	0...600	0...1.000
Overload Pressure P _{max} (bar)	40	200	800	1.200	1.500
Burst Pressure (bar)	50	800	1.700	2.200	2.500
Housing	Ø = 79 mm; T = 33 mm Zinc die casting with rubber TPE protection cover				
Weight (g)	540				
Port	Stainless Steel 1.4404 1/4" BSPP (ISO 228-1)				
Input	Sensor element ceramics (16 bar) Strain gauge pressure measurement cell 10 ms scanning rate Accuracy ± 0,25 % FS typ. ± 0,5 % FS max. + 0,2 %/year A/D converter 12 bit 4.096 steps resolution				
Display	LC text display 4 1/2 digits 50x34 mm Digit size: 15 mm Units: mbar/bar/PSI/Mpa/kPa Back lit illumination Bar graph (trailing indicator) with peak & hold function (analog output on request)				
Sealing	NBR				

Technical Data	
Parts in Contact with Media	Stainless Steel 1.4404, NBR, ceramic
Functions	Units: mbar/bar/PSI/Mpa/kPa MIN/MAX - FullScale Battery level display Auto Power Off/On Zero (zero point equalization) Reset (Delete MIN/MAX)
Power Supply	2 x 1,5V alkaline batteries Battery life typ. 1.500 h
Ambient Temperature (°C)	-10...+50
Storage Temperature (°C)	-20...+60
T _{max} Fluid (°C)	+80
Rel. Humidity	< 85 %
Protection	EN 60529 (IP 67)
Vibration	IEC 60068-2-6/10...500 Hz; 5 g
Shock Load	IEC 600068-2-29/25 g; 11 ms
Reliability Cycles (10 ⁶)	100

- Easy operation
- Prevention of measuring errors due to automatic sensor recognition
- Printer and PC connection
- Two-line display
- Rugged design



The **Serviceman** has 2 inputs for sensors. This enables a differential pressure measurement by pressing only one key. Fast comparisons of actual and set values are done very easily.

The **Serviceman** is extremely robust and insensitive to dirt, so that it can be used in even the toughest conditions. The digital display avoids reading errors.

The **Serviceman** is small and light:
perfect for mobile applications.

Serviceman incl. external power supply
2 Inputs (5 pin) incl. PC Interface

The data output can be used to connect a PC. Data printout is valid under the documentation obligatory under ISO 9001.

The Min/Max memory permits the reading of peak values. Pressure peaks which could lead to damage are detected. **Please note:** The **Serviceman** cannot display negative pressures and flow volumes. If an SCPT sensor is connected, only the pressure signal could be displayed. For temperature measurement please use a separate sensor.

Like all other **SensoControl**® measuring devices, the **Serviceman** is provided with sensor recognition. The measuring ranges are automatically scaled and units shown on the display. This avoids measuring errors and time-consuming adjustment work.

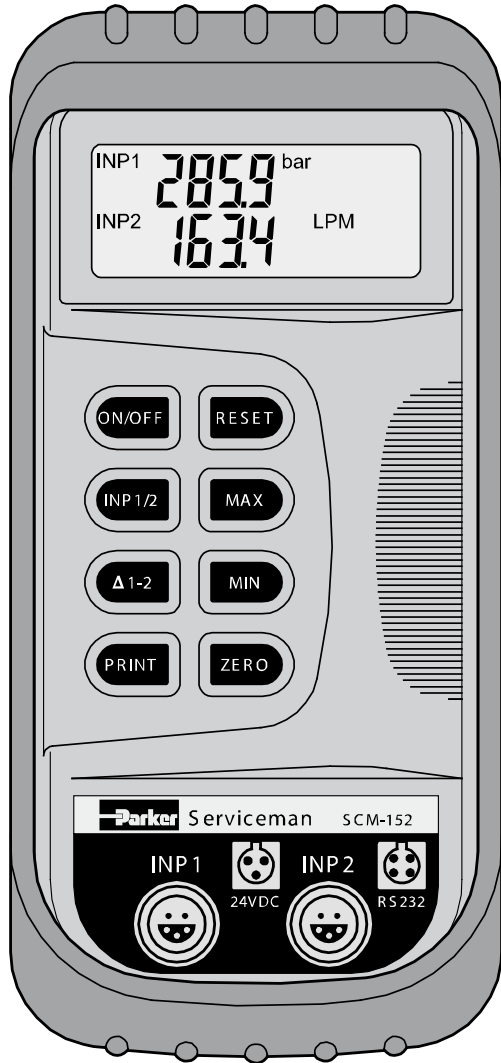

- DISPLAY (two line)
INP1 and INP2; ΔP display
Battery level display
- ON/OFF** On/off switch
- INP 1/2** Select button for input
- Δ 1-2** Differential value display
e.g. P1 - P2 = ΔP
- PRINT** Data transfer to PC
- RESET** Delete MIN/MAX-readings
INP1 = INP2:
Equalisation of ΔP-measuring
- MAX** Maximum value (pressure peaks)
- MIN** Minimum value
- ZERO** Zero point equalisation
- INP1/INP2 Sensor inputs
5-pin = push pull
- 24 VDC Power supply connection or
automotive cable adapter
SCK-318-05-21
- RS232 PC interface
SCM-152-2-02

Serviceman version	SCM-152-0-02	SCM-152-1-02	SCM-152-2-02
PC interface	—	—	●
110/240 VAC SCSN-450 power supply unit included in delivery	—	●	●

Replacement parts and accessories (must be ordered separately)			
Power supply	SCSN-450	—	●
Car cable adapter (12/24 VDC)	SCK-318-05-21	—	○
PC-connection cable (RS232)	SCK-315-02-31	—	○
Rechargeable battery	SC-811	—	○
Battery	SC-812	○	○

- not available
- Option
- Included

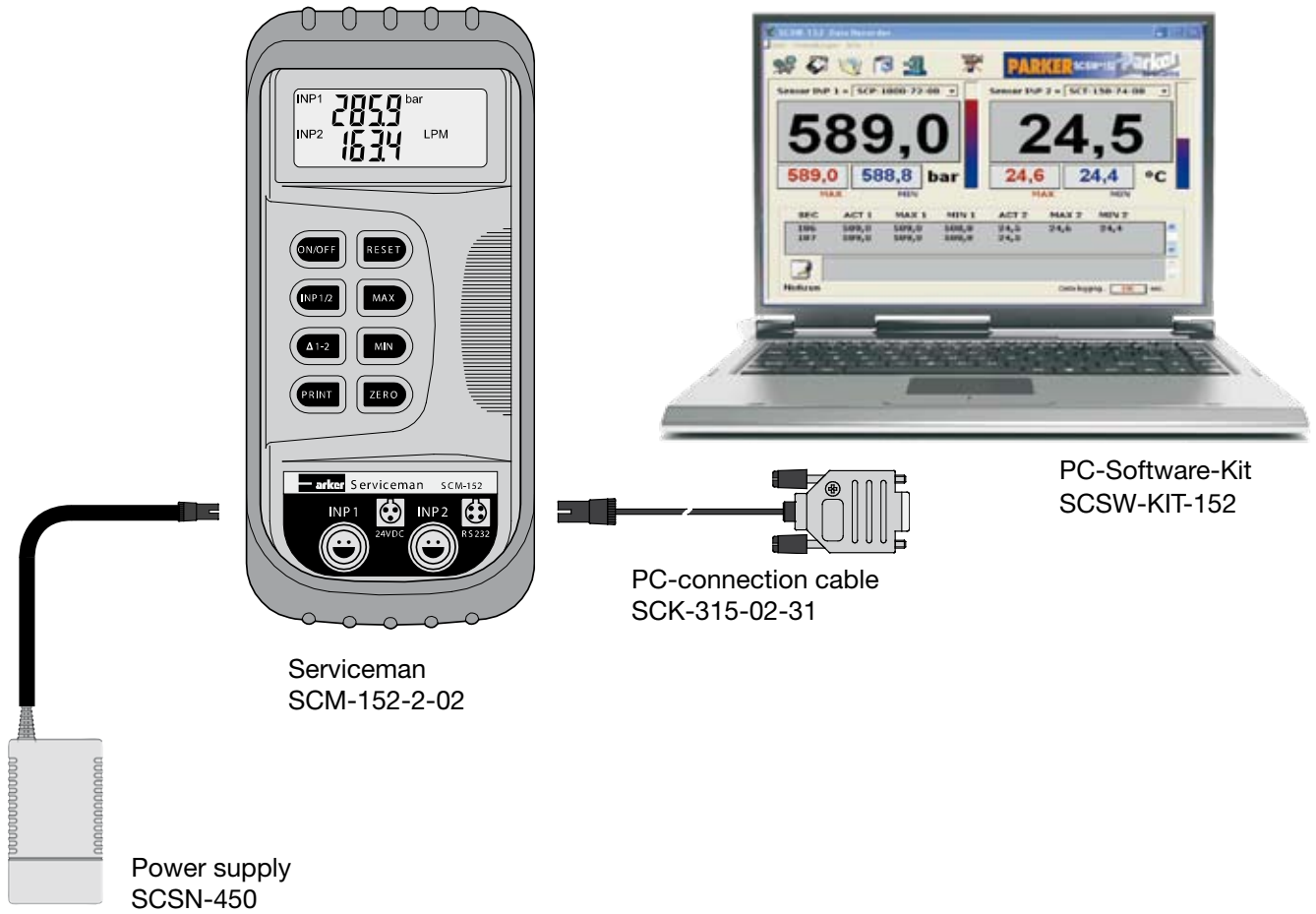

- Easy operation
- Self running installation
- On-line data recording
- Storage of readings in MS Excel format
- Analysis of data with standard software
- Print out readings on site

With the PC Software data transfer from Serviceman to PC or laptop is possible.

The software included is compatible with MS Windows 98/2000/XP.

Recorded data can be further processed and analysed with standard software (e.g. MS Excel).

	Serviceman	SCM-152-0-02	SCM-152-1-02	SCM-152-2-02
Input	2 sensor inputs (5-pin) push-pull (Connection of auxiliary sensors with SCMA-VADC-600)	●	●	●
Connectable sensors	Pressure*, temperature, RPM, flow	●	●	●
Accuracy	±0,25 % FS ±1 Digit	●	●	●
Display	LC text display (4 digit), 2 line, digit size 8 mm	●	●	●
Interface	RS232 (4 pin) optional with a standard RS232/USB PC adapter	—	—	●
Functions	MIN-/MAX display Zero point equalisation INP1-INP2 differential reading Battery level display Auto power off (15 min)	●	●	●
Ambient conditions	Operating temperature: 0...+50 °C Storage temperature: -20...+60 °C Rel. humidity: < 85 % Protection acc. to (EN 60529) (IP54)	●	●	●
Power supply	External power supply SCSN-450 or car cable adapter SCK-318-05-21 (12/24 VDC) Internal battery 9 V/110 mA/h Battery life 5 h	—	●	●
Housing	ABS with rubber protection Dimensions: 170x78x51 mm (L/W/H) Weight: 330 g	●	●	●

* negative pressure cannot be displayed

— not available

● Included

- Digital pressure measurement and back-lit display
- Displays pressure peaks (10 ms) both numerically and graphically
- Measured value memory for storing pressure sequences (5000 measured values)
- Transfer of the stored memory content of up to 16 devices to PC (USB) via radio-wave interface
- Analysis and modification of measured data with "JuniorWin" PC software



Innovative memory technology

ServiceJunior wireless is a real innovation: Pressure values can be measured, displayed and stored.

The **ServiceJunior wireless** – with its unique, intelligent memory management – is capable to record individual or multiple pressure values from the machine or installation.

Stored data is transmitted to a PC via distances of up to 150 meters. The "**JuniorWin**" PC could be used to set the limit value (REC Auto function) and the desired configuration. This allows applications under harsh conditions with up to 1000 bar working pressure.

ServiceJunior wireless allows you to save time and costs when monitoring machines and installations comfortably from your plant office.

Additionally you can analyse and archive the data on your PC.

The device is ideal for monitoring, maintaining and servicing machines and installations in industrial and mobile hydraulic systems.



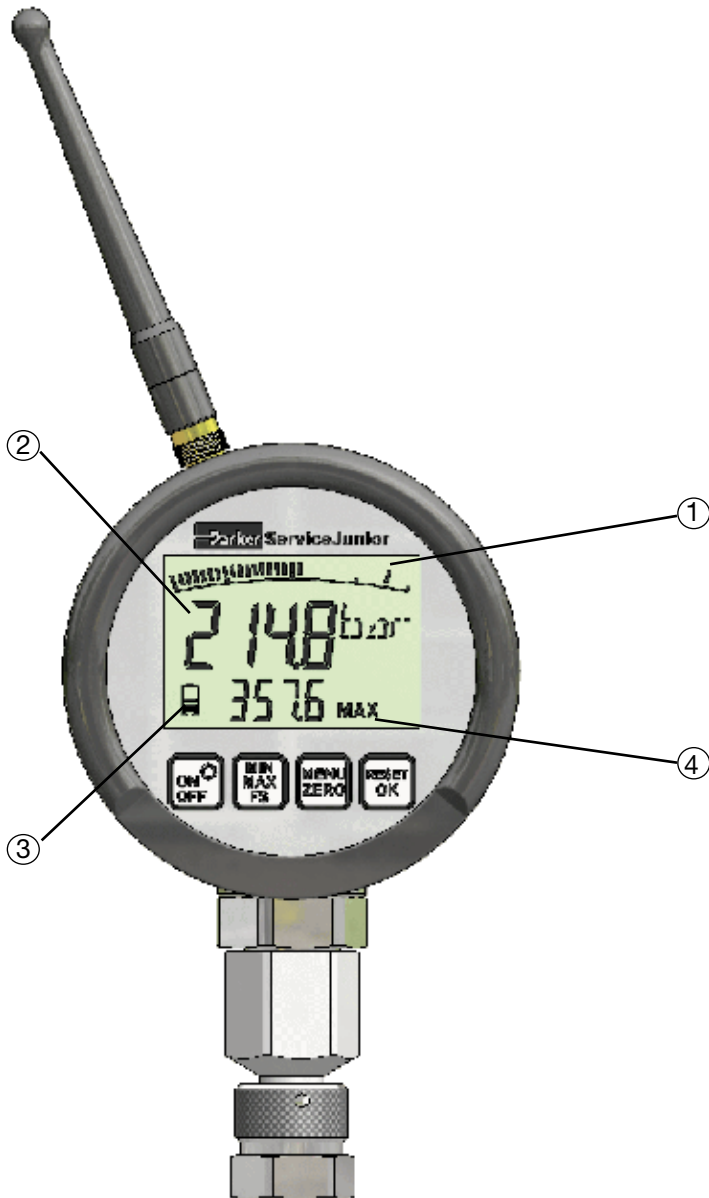

- ① Trailing-indicator display with bar-graph due to peak & hold function
- ② Actual value back-lit display (15 mm)
- ③ Battery level display
- ④ Display of MIN/MAX or Full Scale Range display (FS)

Menu functions

- ON/OFF** On/off switch
Back-lit display
- MIN/MAX/FS** Minimum/maximum value/
FullScale
- MENU/ZERO** Menu: auto shut-off
Choice of units
Zero: Zero point correction
- RESET/OK** Delete MIN/MAX value
Confirm menu function

ServiceJunior wireless	
ServiceJunior wireless (with radio-wave interface):	
Range: -1...016 bar/0...100 bar/0...400 bar/0...600 bar/0...1.000 bar	SCJNP-xxx-01-RC
1 ServiceJunior wireless (acc. to pressure range) 2 batteries 1,5 V alkaline 1 adapter SCA-1/4-EMA-3	

See page 77 for kits and equipment cases.

The ServiceJunior *wireless* system

- PC adapter for sending and receiving data (1)
- Wireless transmission of parameters and data
(Exporting the measured value memory)
- Pressure monitoring for up to 16 measurement points (2-4)

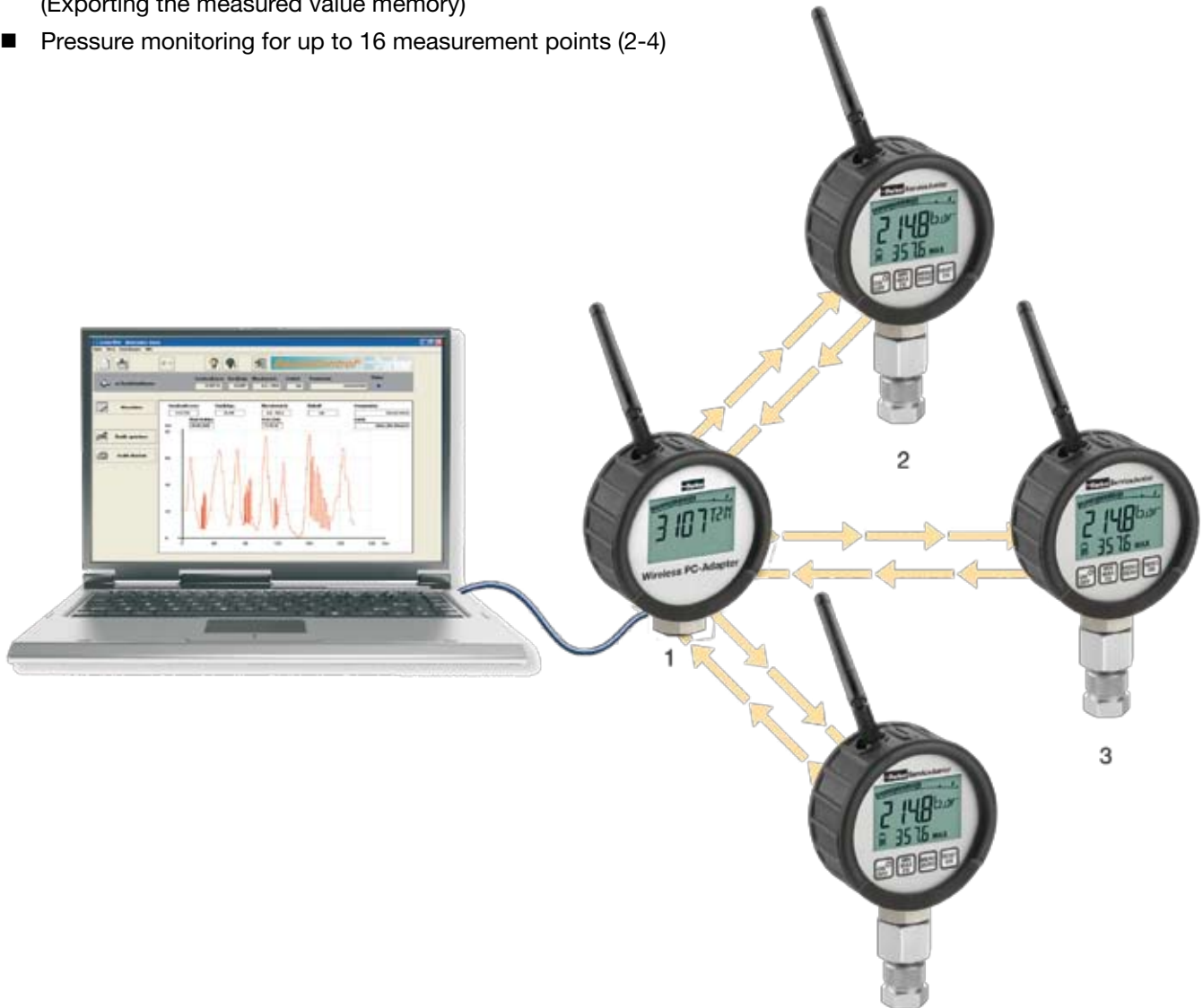

- **Long-term monitoring**
Damaging events can be documented.
This enables quick and precise troubleshooting (peak pressure measurement).
- **Storage of measurement data**
Saves user-defined critical pressure ranges
- **Radio-wave transmission up to 150 meters**
Enables cable-free installation on difficult-to-reach sites (such as rotating equipment).
The measured location and the location for recording measurements do not need to be close together.
- **Saves costs during diagnostics**
Simple and easy to install (battery operated, no cabling)

Memory functions

An example recording measurement with the REC Time/ REC Auto setting

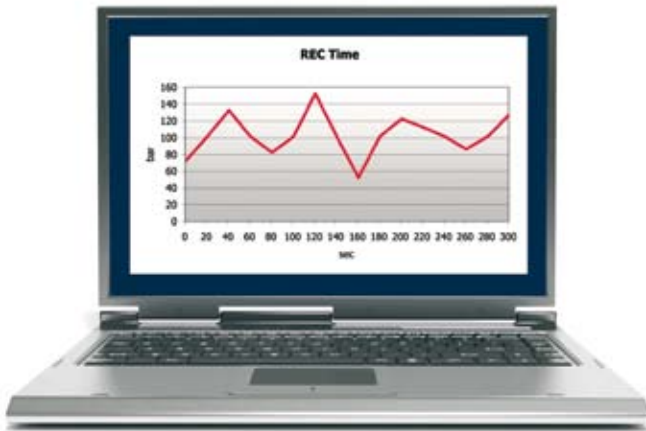

REC Time:

Recording time (e.g.) 300 s ÷ 5000 intervals

- Interval = 60 ms
- 10 ms scanning rate = 6 measurements
- The maximum value (MAX) is determined from these measurement values and then saved
- 5000 (MAX) measured values are saved

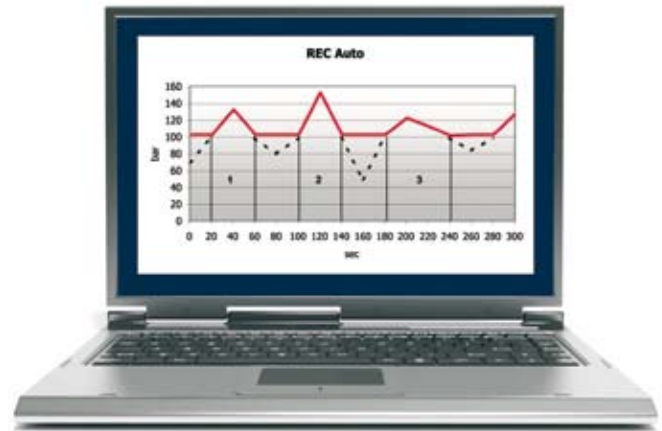

REC Auto:

Monitoring / control of pressure values

All pressure values exceeding a limit value (e.g., 100 bar) are saved within a defined recording interval (e.g., 100 ms).

10 ms scanning rate = 10 measurements

The maximum value (MAX) is determined from these measurement values and then saved.

1 = 101 bar

2 = 102 bar

3 = **108 bar MAX** value

This measured value is then saved for this interval (100 ms).

All other measured values are deleted.

...

9 = 105 bar

10 = 104 bar

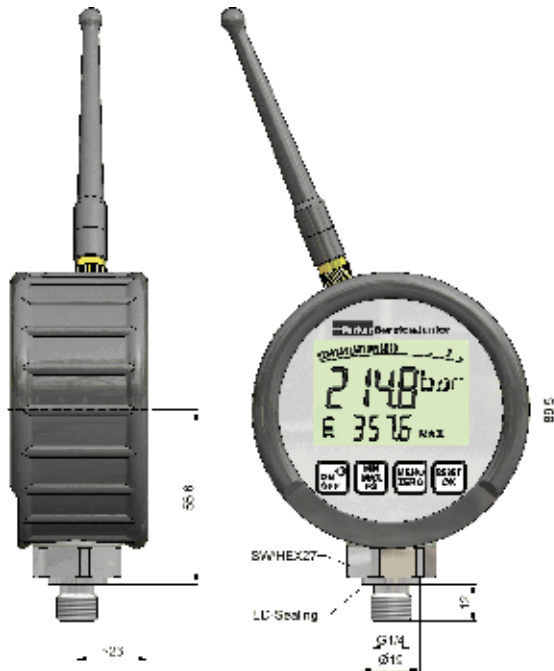

Technical Data					
SCJNP	016	100	400	600	1000
Range (bar)	-1...16	0...100	0...400	0...600	0...1.000
Overload Pressure P _{max} (bar)	40	200	800	1.200	1.500
Burst Pressure (bar)	50	800	1.700	2.200	2.500
Housing	Ø = 79 mm; T = 33 mm Zinc die casting with rubber TPE protection cover				
Weight (g)	540				
Port	Stainless Steel 1.4404 1/4" BSPP (ISO 228-1)				
Input	Sensor element ceramics (16 bar) Strain gauge pressure measurement cell 10 ms scanning rate Accuracy ± 0,25 % FS typ. ± 0,5 % FS max. + 0,2 %/year A/D converter 12 bit 4.096 steps resolution				
Display	LC text display 4 1/2 digits 50x34 mm Digit size: 15 mm Units: mbar/bar/PSI/Mpa/kPa Back lit illumination Bar graph (trailing indicator) with peak & hold function (analog output on request)				
Sealing	NBR				

Technical Data	
Parts in Contact with Media	Stainless Steel 1.4404, NBR, ceramic
Functions	Units: mbar/bar/PSI/Mpa/kPa MIN/MAX - FullScale Battery level display Auto Power Off/On Zero (zero point correction) Reset (Delete MIN/MAX)
PC-Function	PC Software "JuniorWin" Download data from memory to PC via radio interface (2,4 GHz) Operation range 150 m (clear range) Setup of recording parameters IEEE 802.15.4 radio approval
Memory Function	5.000 Readings (MAX pressure peaks) Setup of storage interval REC TIME (Time based recording) REC AUTO (Pressure spike monitoring)
Power Supply	2 x 1,5V alkaline batteries Battery life typ. 800 h
Ambient Temperature (°C)	-10...+50
Storage Temperature (°C)	-20...+60
T _{max} Fluid (°C)	+80
Rel. Humidity	< 85 %
Protection	EN 60529 (IP 54)
Vibration	IEC 60068-2-6/10...500 Hz; 5 g
Shock Load	IEC 600068-2-29/25 g; 11 ms
Reliability Cycles (10 ⁶)	100

- Instruments with 3-channel and 4-channel technology
- Easy operation due to automatic sensor recognition
- PC interface
- Powered by rechargeable battery
- Rugged design



The Parker Service Master *Easy* is a multi-channel hand meter for the simultaneous measuring of important hydraulic values:

All hydraulic parameters such as pressure, differential pressure, flow and hydraulic power can be measured, displayed, stored and processed.

To meet the requirements of both modern industrial hydraulics and complex mobile hydraulics, we offer a range of different models:

Parker's portable measuring instruments can be used in three different versions:

1. Measuring and readout

Through automatic sensor recognition all measured values are shown immediately on the display. Each input can be used as required. The display switches automatically to the appropriate line size.

- **Peak pressure measurement (MIN/ MAX display)**
The scanning rate of 1,000 measurement values/s captures rapidly occurring pressure peaks within the space of a millisecond. The Parker Service Master Easy can also be switched into fast mode.
- **Differential pressure measurement**
Exact Δp measurement is achieved by means of the Δp adjustment. Under operating pressure the

deviation of the pressure sensors relative to each other is corrected. For load sensing control the exact Δp setting is a prerequisite for trouble-free functioning of the hydraulics. A combination of Δp (bar) and flow Q (l/ min) is displayed as hydraulic power P (kW).

- **External sensors**
Analog signals such as those from a force or stroke sensor (external sensor) can be measured using external modules. Electrical currents or voltages (like those from proportional valves) can also be captured.

2. Data logging and recording

The recording (storage) of measurements provides documentation of settings and the actual condition of the hydraulics. Measurements can be further processed on a PC with SensoWin® software. This is ideal for customer care or service since the measurements can be called up at any time.

With the special storage technology, all pressure peaks in the hydraulic system can be captured independently of the set measurement time (storage time). Within each storage interval one min. and one max. value is stored. The user has only to pre-select the measuring time. Individual setting of the storage interval is likewise available (for example, 10 ms).

- **Start-stop function**
The start and finish of measurements are controlled by the start/stop key only. The two buttons can be used to quickly and easily save the measured values. No additional default settings are needed.

- **Program-controlled recording**
Various programs may be selected:
 - Auto-trigger:
Recording starts by pressure increase (60 bar, increasing slope)
 - Manual: Start by pressing enter key
 - Point-to-point measurements: Save individual measurements with the press of a button.

Various save functions can be selected with the particular starting conditions. All the connected channels (sensors) are measured and stored. Program-controlled storage is particularly advantageous during the search for faults in hydraulic machinery. The point when the cause of damage occurs (for example, pressure peak or pressure drop) is not as a rule foreseeable. With the help of SensoWin® the recording can be subsequently analysed exactly.

3. OnLine Operation

In On-line operation all measurement values are transferred directly to a PC and subsequently stored. The current graphic display in SensoWin® allows the hydraulics to be set (valve position or pressure load) whilst the test is running.

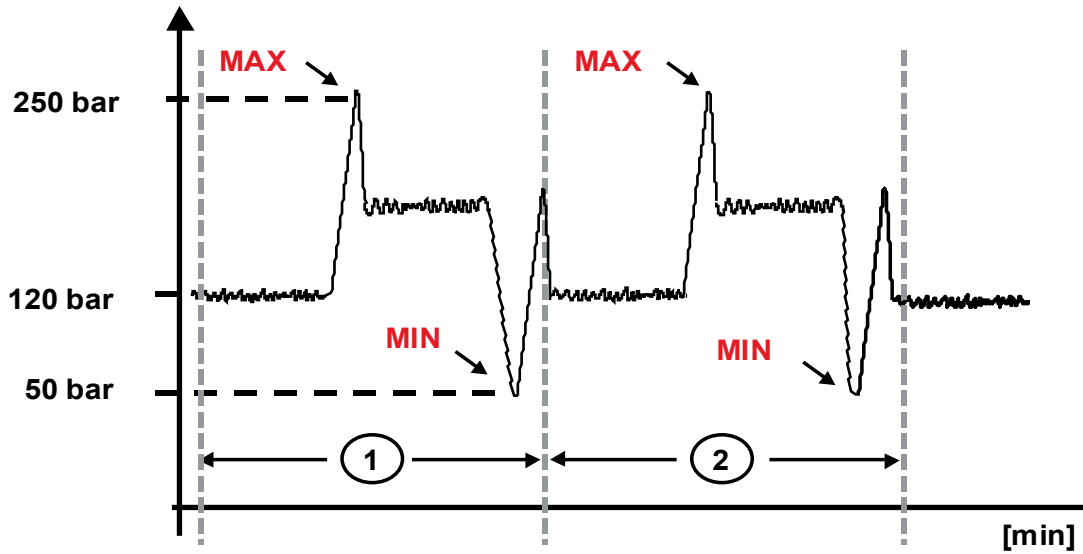

Dynamic MIN-MAX record/save:

For each sensor (channel) up to 2,000 memory intervals could be created with **The Parker Service Master Easy**. Each memory interval saves a pair of data points consisting of one MIN and one MAX value.

Running a constant scanning rate of 1,000 readings/s this will correspond to 300 readings (interval). The highest (max) and lowest (min) will be carried to the measurements memory.

In a recording session of 10 min and 2,000 intervals, the length of each storage interval is 300 ms.

The connection of these data points creates a measured graph and guarantees the capture of pressure peaks.

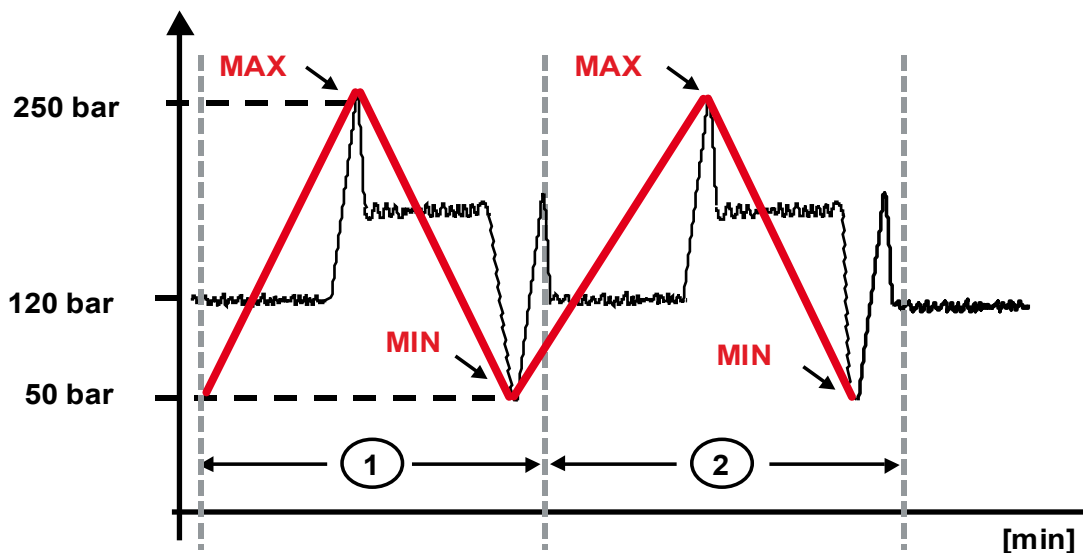

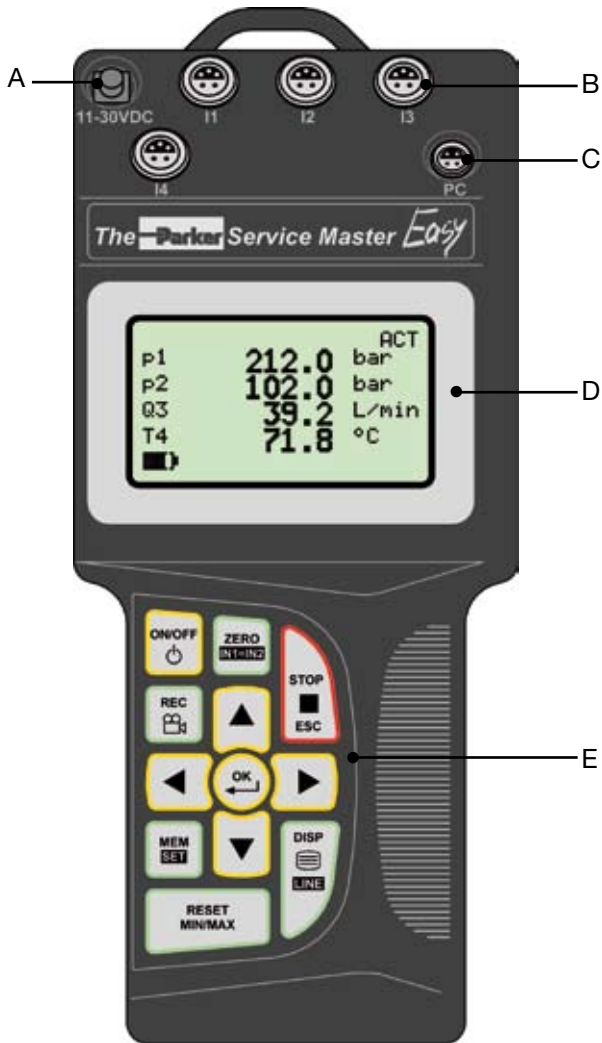

A 11-30 VDC
Power supply 110/230 VAC-15 VDC
Car cable adapter 12/24 VDC

B I1 – I4
Sensor connection

C PC (USB)

D Display

E Keyboard



ON/OFF



Confirmation function/value



Selection of the function or value



STOP/ESC

Menu keys



ZERO Zero-point correction
IN1 = IN2 Differential value alignment



MEM SET Memory configuration
Main menu (device settings)



DISP MIN-MAX/ACT or FS display
LINE Display configuration



REC Measured value recording



RESET the MIN/MAX values

The Parker Service Master Easy with Power Supply SCSN/SensoWin Software/PC Cable		
The Parker Service Master Easy 3-channel		SCM-330-2-02
The Parker Service Master Easy 4-channel		SCM-340-2-02

Spare Parts/Accessories		
Power Supply	110/230 VAC EUR/UK/US	SCSN-450
Car Cable Adapter	12/24 VDC	SCK-318-05-21
PC-Connection Cable	USB	SCK-315-02-34
Rechargeable battery		SC-BAT-340

	The Parker Service Master Easy	
Input	With sensor recognition (p/T/Q/n) Adapter for external sensors 0...10 V, 0/4...20 mA (Use SCMA-VADC-600 adapter for connecting external sensors.) Plug-in connection: 5-pin, push-pull Resolution: 12 bit + sign = 4,096 steps	
Accuracy	±0,2 % FS ±1 Digit	
Sampling period	1 ms 0,25 ms FAST MODE (IN1)	
Display	Graphic LC Resolution: 128 x 64 pixels Visible area: 72 x 40 mm Back-lit display Digit size: 6 mm (for 4 line display) Accuracy of display: < 0,25 % FS	
Display functions	Difference; addition; power; volumes ACT; MIN; MAX; FS; TEMP display; Battery status	
Operation	Foil-covered keyboard with mechanical tactile touch and embossed edges	
Interface	USB 2.0, compatible with USB 1.1 Min. 5 ms online data transmission ACT-MIN-MAX	
Measured value memory	Measured value memory:	1000000 Points
	Curve memory:	240000 Points
	Data format	ACT MIN-MAX FAST (0,25 ms) IN1
	Memory configuration:	Intervall (e. g. 5 ms) Points/Channel (2.000)
Ambient conditions	Temperature range:	0 ... 50 °C
	Storage temperature:	-25 °C ... 60 °C
	Temperature error:	0,02 % / °C
	Rel. humidity:	< 80 %
	Protection according to:	EN 60529 IP 54 (water spray/ oil)
	Drop test:	IEC 60
CE	DIN / EN 61000-6-2 DIN / EN 61000-6-3	
Power supply (external)	11 ... 30 VDC Power supply 110/240 VAC-15 VDC Car cable adapter (12/24 VDC)	
Battery	NiMH Battery life: about 8 hours with 3 sensors	
Housing	Polyamid; 235 x 106 x 53 mm; Weight: approx. 530 g	
PC software	Download, display and analyze measured data on PC Download and edit device settings Load device settings from library onto portable measuring instrument	

- Portable multi-function hand-held measuring instrument
- Pressure, temperature, flow and speed can be measured, monitored and analysed.
- Measurement and display of over 50 channels.
- Measured value display: numerical, bar graph, pointer, curve graph
- Project templates can be saved and loaded.
- Interfaces: CAN, LAN, USB
- Total memory with up to 1 billion measured values
- Measured data can be (automatically) recorded, saved and analysed with the **SensoWin® 7 PC software and a LAN or USB connection.**



The application possibilities for hydraulics have recently increased throughout all areas of drive and control systems. This trend has been particularly noticeable in the sectors of machine, plant and automotive construction. At the same time, hydraulics and electronics have become increasingly intertwined. Parker's new hand-held measuring instrument – **The Parker Service Master Plus** – helps you to deal with these new trends. It has never been so easy to follow the complex processes in these sectors with measurement, display and analysis. Potential uses include preventative maintenance, commissioning, troubleshooting and machine optimization.

The expanded requirements of these modern applications (such as the increased number of measurement points, longer cable lengths and high noise immunity) have driven further development of the CAN bus. Parker's CAN bus sensors now take advantage of the bus system's automatic sensor detection capability to provide an easy-to-install Plug & Play solution. Compatibility with existing diagnostic sensors is also provided.

Our proven storage strategy is focused on MIN and MAX value measurements. Combined with a wide variety of value presentation styles, these features make effective solutions-oriented analysis possible.

The **SensoWin®** PC software offers additional methods for analysis, control and remote maintenance using LAN and USB connections. Together with this software, **The Parker Service Master Plus** is a truly user-friendly measuring instrument that can be used for any type of diagnostics application.



110/240 VAC power supply, battery life 8 hours, recharging time 3 hours

2 x CAN-busnetworks with up to 32 channels

Modular design for up to 16 analog channels or 2 Highspeed channels (0,1 ms) automatic sensor recognition

PC Interface (USB 2.0); ACT/MIN/MAX measured value transmission to the SensoWin® software, terminal for USB mass storage devices

LAN interface for remote monitoring, micro SD memory card for storage enlargement

High protection from moisture and dirt thanks to cover caps and a rubber protective sleeve, Protection Class IP64

Easy to carry and hang up with carrying strap

Portable multi-function hand-held measuring instrument – strong in design and tough in operation

Illuminated display for good readability in any situation

Large keyboard and fonts for easy operation and readability

Ergonomic housing shape ensures convenient portability and long operating times

Protection of the housing, affording usage in tough environments and absorption of shocks

Big 5.7 inch colour display for clearly viewing the extensive information

Intuitive operation thanks to clear-cut control elements and function-oriented keys

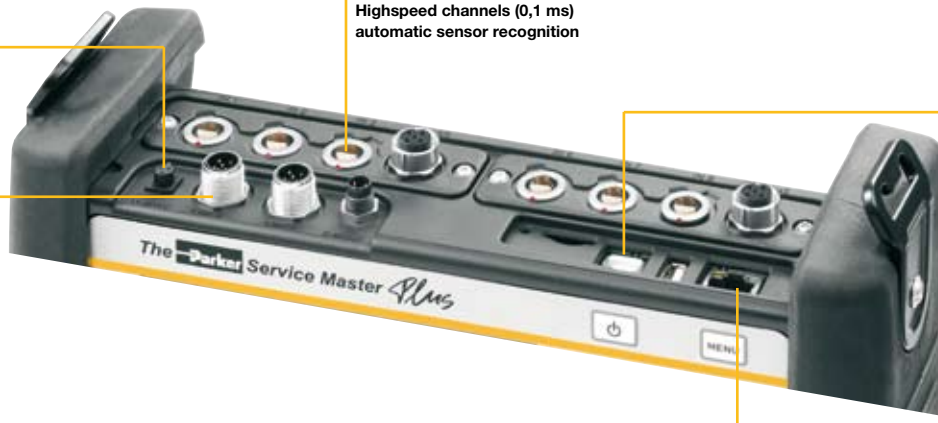

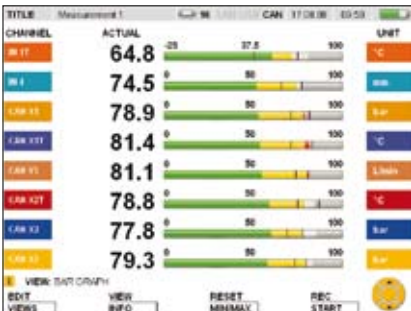
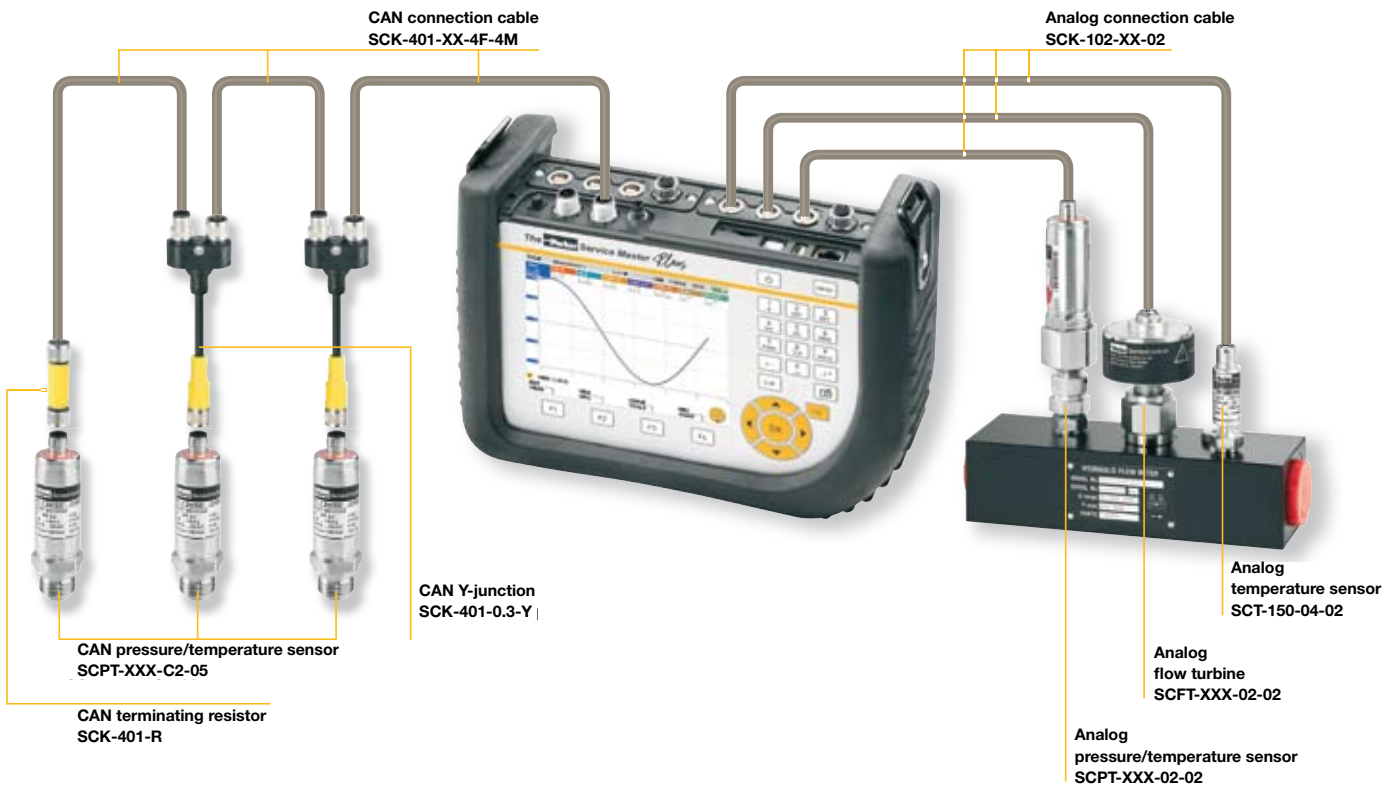

- Display of measured values as figures and bars
- Fixing of alarm ranges in green, yellow and red
- Trailing pointer function with MIN and MAX values

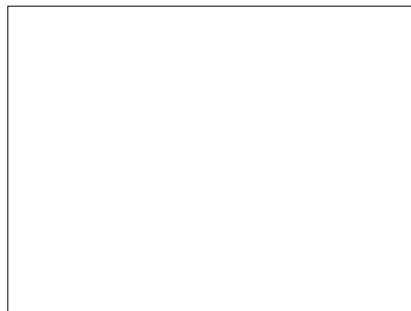

- Up to 4 channels in one large-format display
- Simultaneous display of ACT, MIN and MAX values
- Information lines for current settings, events and views
- Individual measurement channel identifier



- Up to 8 channels in one display
- Colour allocation of the individual channels
- Uniform headings with measurement titles, sensors connected, interfaces, date, time and battery condition indicator
- Display can be changed between MIN and MAX values and full scale



- Up to 8 channels in one graph display
- Fine, precise graph image thanks to high definition display
- Choice between ACT and MIN/MAX value display
- Automatic and manual scaling of the time axis for optimum measured value display

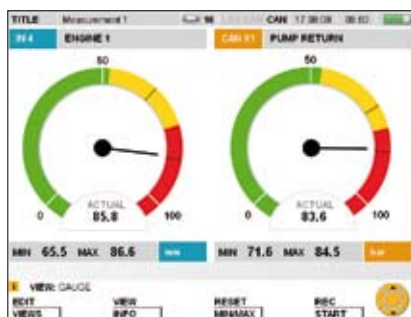

- Large-area pointer display of measured values
- Trailing pointer for MIN and MAX values
- Alarm range in green, yellow and red
- Further channels can be called up with the arrow keys

The Parker Service Master Plus – Basic unit SCM-500-00-00	
Inputs/outputs	<p>CAN sensor inputs 2 CAN bus networks each with 16 channels (for Parker CAN-Bus sensors) Scanning rate 1 ms = 1000 measured values/sec. M12x1 push-in connector, 5-pin with SPEEDCON®</p> <p>1 digital trigger input Scanning rate: 1 ms Input impedance: 1 kohm Active high: >+7 VDC...+24 VDC Active low: <1 VDC Isolated</p> <p>1 digital trigger output Scanning rate: 1 ms Output signal: +24 VDC/max. 20 mA Isolated Push-in connector for digital input and output: M8x1, 4-pin, male</p>
Module slots	<p>2, for input module, flexible placement possible Slot 1 = IN1, IN2, IN3, IN4/5 Slot 2 = IN6, IN7, IN8, IN9/10</p>
Display	<p>FT-LCD colour graphic display Visible area: 115 x 86 mm Resolution: 640 x 480 pixels</p>
Interfaces	<p>USB device Online data transmission between unit and PC via SensoWin® Measured value transmission: ACT/MIN/MAX USB standard: 2.0, fullspeed Push-in connector: USB socket, shielded, type B</p> <p>USB host Connection for mass storage devices such as USB stick or removeable hard disc Standard: 2.0, fullspeed, 100 mA max. Push-in connection: USB socket, shielded, type A</p> <p>Ethernet Online data transmission between unit and PC via SensoWin® and remote control Measured value transmission: ACT/MIN/MAX Standard: 10, 100 Mbit/s, IEEE 802.3 (10/100 base T) Push-in connection: RJ45, socket, shielded</p>
Functions	<p>Measurement: ACT, MIN and MAX values Measured value display: Numerical, bar graph, pointer, curve graph Measuring functions: Start/stop, points, trigger</p> <p>Trigger: Slope, manual, level, window, time, logic (interconnection of up to two events for the measurement start and stop) Pre-Trigger</p> <p>Remote operation via the Ethernet Acoustic notification at any incident</p>

SPEEDCON® Registered Trademark of PHOENIX CONTACT GmbH & Co. KG

The Parker Service Master <i>Plus</i> – Basic unit SCM-500-00-00	
Measured value storage	<p>For storing measured values, project data and screen copies (screenshots)</p> <p>Storage capacity ≤ 4 million measured values per measurement Total measured value storage > 1 billion measured values</p> <p>Storage format: ACT/MIN/MAX Storage interval: 1 ms to 24 h Storage duration: 1 ms to 300 h (trigger measurement)</p> <p>Internal 64 MB (approx. 32 million measured values)</p> <p>External: SD storage 2 GB (1 GB Micro SD memory card included in standard shipment) Slot: Micro SD memory card</p> <p>External: USB mass storage device 40 GB</p>
Ambient conditions	<p>Operating temperature: 0...+50 °C Storage temperature: -25...+60 °C Relative humidity: < 80 % Environmental test: IEC60068-2-32 (1 m, free fall)</p>
Type of protection	IP64 (to EN60529)
Power supply	<p>Internal Lithium ion pack, +7.4 VDC/4500 mAh Battery charging circuit/operating time with 3 CAN sensors: > 8 h</p> <p>External 110/240 VAC - 24 VDC/2500 mA Vehicle adapter cable as accessory (12/24 VDC)</p>
Housing/protective sleeve (incl. in standard shipment)	<p>Housing material: ABS/PC (thermoplastic) Housing protective sleeve material: TPE (thermoplastic elastomer) Dimensions (w x h x d): 257 mm x 75 mm x 181 mm Weight: 1550 g (basic model)</p>

The Parker Service Master Plus – Typ 01 input modul	
Inputs with sensor recognition	<p>3 sensor inputs (up to 6 analog measurement channels) with sensor recognition (p/T/Q/n) for SensoControl® diagnostic sensors also connection of auxiliary sensors possible with SCMA-VADC Push-in connection: 5-pin, push-pull, combination panel plug/socket Scanning rate: 1 ms = 1000 measured values/sec.</p> <p>For the SCPT combined pressure & temperature sensor, there is an additional temperature channel for each sensor input Temperature scanning rate: 1 s</p>
Inputs for auxiliary sensors	<p>2 analog sensor inputs for measuring current and voltage Scanning rate: 1 ms = 1000 measured values/sec. Voltage measuring range: -10...+10 VDC (freely configurable) Current measuring range: 0/4...20 mA Supply external sensors: +18...+24 VDC/max. 100 mA Push-in connection: M12x1, 5-pin socket</p> <p>FAST mode Scanning rate: 0.1 ms = 10,000 measured values/sec. only one auxiliary sensor input is useable</p>
Accuracy	±0,25 % FS + 0,02 % per °C

Product overview				Additional items available:
	CAN-sensor inputs	Sensor inputs with sensor recognition (analog)	External sensor inputs (analog)	<ul style="list-style-type: none"> - Installed handle - 24VDC/2.5A power pack incl. country adapter - M8x1,4-pole cable socket - USB 2.0 cable (2 m) - LAN cable (5 m) - Operating instructions - PC Software - 1 GB microSD-memory card
SCM-500-00-00 (Basic unit without input module)	2 networks each with 8 sensors max	0	0	
SCM-500-01-00 (Basic unit with 1 input module type 01)	2 networks each with 8 sensors max	3	2	
SCM-500-01-01 (Basic unit with 2 input modules type 01)	2 networks each with 8 sensors max	6	4	

- Easy operation
- Windows® 2000/XP/ VISTA
- Simultaneous representation of 16 curves
- Zoom functions
- Linking of measuring curves
- Tabular listing of measured values
- Calculation of extreme value
- Curve shifting function
- Free selection of units and measuring ranges
- Cursor functions
- Transmission of set-up parameters from The Parker Service Master
- Automated measurement procedure and documentation print-out



General

The **SensoWin®** software is an easy to operate software package for reading and processing the measured curves recorded by **The Parker Service Master Easy** or **The Parker Service Master Plus**.

Documentation and certificates can be created easily and at low cost since **SensoWin®** can make use of all Windows features.

Functions

Up to 16 different curves can be represented in a diagram. The curve shifting function allows exact hydraulics analysis. A power performance curve can be created to evaluate a pump.

Leaks and pressure losses can be detected by generating a differential value function.

With the cursor, a hydraulic procedure can be examined time-dependent. For each curve, extensive information is provided; **The Parker Service Master Easy** or **The Parker Service Master Plus** measurements can be reproduced at any time.

The change of the ranges and units allows later adjustment for presentation in a diagram.

Tabular presentation of ACT/MIN and ACT/MAX values, smoothing of the measurement curve and mathematical links are important functions in the analysis of the hydraulic system.

Date and time are documented with each measurement. This considerably facilitates later allocation of values.

Direct transmission of measured values from **The Parker Service Master Easy** or **The Parker Service Master Plus** to the PC is also possible.

Current events (pressure peaks, etc.) are visible while the process is running (on-line function).

Software SensoWin®	The Parker Service Master	
	<i>Easy</i>	<i>Plus</i>
Display: numerical, bar graph, pointer, curve graph	●	●
Simultaneous display of 16 channels	●	●
Oscilloscope / trigger display	—	●
Zoom function	●	●
Calculate function	●	●
Analyse function	●	●
Extended cursor function (Displays X values and corresponding Y values)	●	●
Connection via:	USB	●
	Ethernet	—
Online measured-value display	●	●
Online measured-value memory	●	●
Projects can be saved	●	●
Excel export	●	●
Complete remote control of instrument	—	●
Measurement procedure can be automated (Auto-sequence control)	●	●

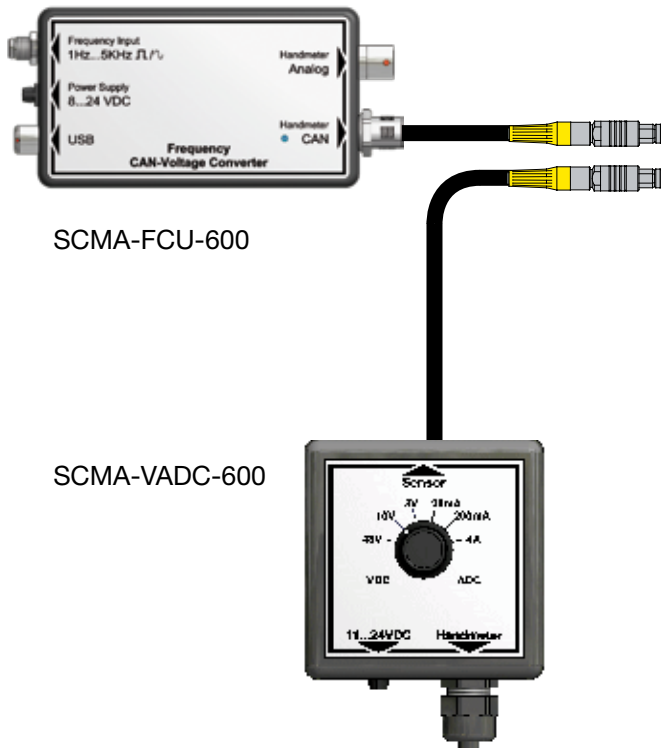

SCMA-FCU-600

SCMA-VADC-600

The Parker Service Master family
or Serviceman

Measurement of electrical signals with
The Parker Service Master

■ Measuring frequency with the SCMA-FCU-600

The SCMA-FCU-600 can be used to connect frequency signals (for example, from turbines, flow counters or tachometers) to the The Parker Service Master Easy or the The Parker Service Master Plus. The instruments can process sinus and rectangle signals from 1 Hz to 5 kHz with signal amplitude from 20 mV to 10 V. Configuration is possible via USB and PC-software.

■ Power supply for the external sensor

An external sensor can be supplied with 24 V using the SCMA-FCU-600.

■ Analog or CAN output

The SCMA-FCU-600 can be connected either to an analog input or a CAN input.

■ Measurement of external signals with the SCMA-VADC-600

Signals such as 0/4...20 mA or 0...10 V from auxiliary sensors, (for example, for torque, power or stroke) are connected to the TheParker Service Master.

Typical applications:

- Force/path diagram
- Torque/flow volume nominal lines

■ Current/voltage measurement

Electric currents up to 4 ADC and voltages up to 48 VDC can be measured with this module.

Applications:

- Current consumption of a proportional valve
- Measurement of switch status in motors/pumps

Technical Data		
	SCMA-FCU-600	SCMA-VADC-600
External sensor port		
Measuring range	1 Hz...5 kHz, Sinus and rectangle signals 40 mVpp...10 Vpp	Voltage 3 VDC 10 VDC 48 VDC Current 20 mA 200 mA 4.000 mA
Sensor power supply	24 VDC \pm 0,5 VDC	18 VDC \pm 0,5 VDC For external voltages higher than 18 V DC: Power supply = sensor power supply
$I_{Out (Max)}$ without power supply	50 mA	50 mA
$I_{Out (Max)}$ with power supply at 24 VDC	100 mA	100 mA
Accuracy	1 % FS \pm 0,05 %/°C	0,5 % FS \pm 0,02 %/°C 1,5 % FS at 4 A measurement range
Power Supply		
Power supply (external)	8 ...24 VDC	11 ...24 VDC
Connections		
Sensor	4-pol., M8, plug (Female with screw-in connections included with delivery)	4-pol., M12x1, female (Connection cable with banana jack included with delivery)
External power supply	3-pol., female	3-pol., female
USB	4-pol., female	-
Analog	5-pol., female	Fixed cable
CAN	5-pol., M12	-
Housing		
Dimensions	114 x 64 x 26 mm	67 x 68 x 28 mm
Ambient conditions		
Operating temperature	0 °C up to 60 °C	0 °C up to 60 °C
Storage temperature	-25 °C up to 70 °C	-25 °C up to 70 °C
Rel. Humidity	< 80 %	< 80 %
Protection class	IP40	IP40

Pressure/Temperature/RPM Measurement

Various sensors are available depending on the measurement requirements.

1 SCPT-type pressure/temperature sensors

- Robust stainless steel design
- Response times of 1 ms
- Capturing of pressure peaks
- Accuracy $\pm 0,25$ % typ.
- Diagnostic adapter







2 SCT-type temperature sensors

- High-pressure-resistant temperature probe for hydraulic measurements
- Measures oil temperatures up to 125°C
- Screw-in or manual probe

3 SCPRM-type tachometer

- Contactless RPM (speed) measurements
- Measure up to 10000 RPMs
- With 2-meter fixed cable



	SCPT	SCPT-CAN	SCT	SCRPM
Intended use				
	Measurement of pressure and temperature in standard applications <ul style="list-style-type: none"> ✓ Stainless steel cell ✓ Higher burst pressure ✓ Resistant to pressure peaks 	Measurement of pressure and temperature in standard applications <ul style="list-style-type: none"> ✓ Stainless steel cell ✓ Higher burst pressure ✓ Resistant to pressure peaks ✓ CAN bus connection 	Measurement of pressure under high operating pressures <ul style="list-style-type: none"> ✓ Unique resistance to pressures up to 630 bar ✓ Compact size ✓ Fast reaction time 	Contactless RPM (speed) measurements <ul style="list-style-type: none"> ✓ Opto-electronic measurement ✓ Installation or adjustment is not necessary
Measuring range	-1...15/0...60/150/400/600/1.000 bar	-1...16/0...60/160/400/600/1.000 bar	-25...+125 °C	50...10.000 RPM
Hydraulic connection	1/2" BSPP		M10x1	
Accuracy	< ±0,5 % FS		< ±1 % FS	< ±0,5 % FS
Electrical connection	5 pin push-pull	5 pin M12x1,5	5 pin push-pull	Fixed cable
Application	Test bench, process engineering, materials handling, loading and lifting systems, general machinery construction and pneumatic or hydraulic installation construction 		Mobile hydraulics/ Industrial conveyor vehicles/utility vehicles/construction machinery/ agricultural machinery 	
Order code	SCPT-xxx-02-02	SCPT-xxx-C2-05	SCT-150-xx-02	SCRPM-xxx
Refer to page	38-40	41-42	43-46	47-49

- Robust stainless steel design
- Response times of 1 ms
- Capturing of pressure peaks
- Accuracy $\pm 0,25$ % typ.
- Flexible operation
- SCPT series



Fast response times guarantee the safe capture of pressure peaks in hydraulic systems. The robust stainless steel construction allows a variety of applications, for example cooling water or pneumatics.

All pressure sensors are delivered with a diagnosis adapter (M16x2) installed. Connection to the hydraulic system takes place quickly and safely. Times for installation are reduced.

Pressure measurements	
-1... 015 bar	Pneumatics/ low pressure
0 ... 060 bar	Medium pressure
0 ... 150 bar	Medium pressure
0 ... 400 bar	Operating pressure hydraulics
0 ... 600 bar	High pressure
0 ... 1.000 bar	High pressure peaks
Temperature measurements	
-25...+105 °C	Oil temperature



The Parker Service Master *Plus*
or The Parker Service Master *Easy*



Serviceman
SCM-152-x-02

Connection cable
SCK-102-03-02

Connection cable
SCK-102-03-02

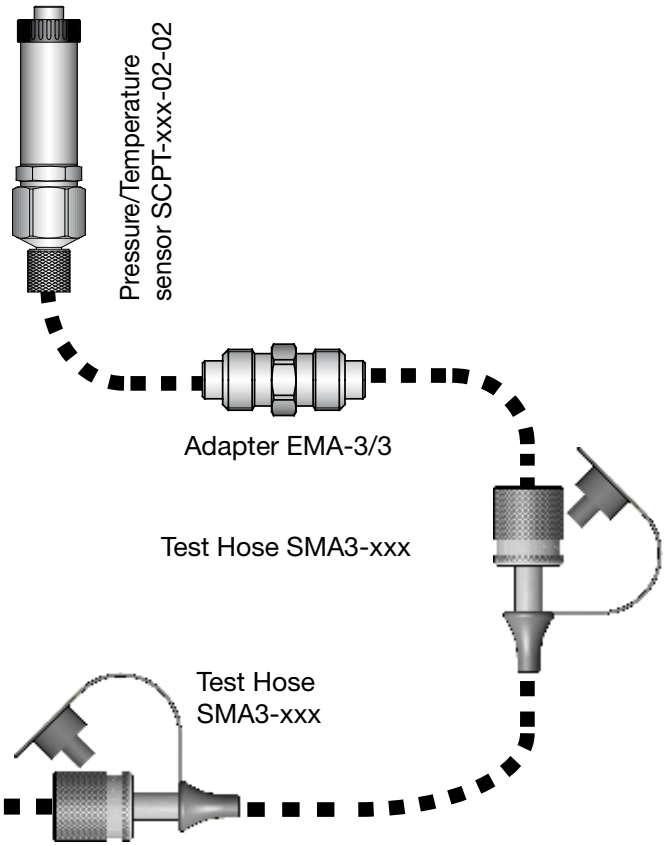

Pressure/Temperature measurement SCPT

There is a selection of various measuring ranges for the measuring of pressures. Sensors can be used for pneumatic applications and also for measuring pressure peaks up to 1000 bar. The pressure/temperature sensors of the SCPT series have a temperature channel which is retrieved via the TEMP key.

Diagnostic adapters

All pressure sensors in a measurement case (kit) are provided with a factory-assembled SCA-1/2-EMA-3 diagnostic adapter. The pressure sensors can be adapted to all standard measuring connections with the help of diagnostic couplings supplied. They are perfectly suitable for a quick and flexible diagnoses in hydraulic applications.

SCPT Pressure/Temperature Sensor 1/2" BSPP male incl. Adapter SCA-1/2-EMA-3	#
-1...015 bar/0...060 bar/0...150 bar/ 0...400 bar/0...600 bar/0...1.000 bar	SCPT-xxx-02-02

SCPT Pressure/Temperature Sensor 1/2" BSPP male incl. Adapter SCA-1/2-PQC	#
-1...015 bar/0...060 bar/0...150 bar/ 0...400 bar/0...600 bar	SCPT-xxx-02-02-PQC

SCK Connection cable Serviceman/The Parker Service Master Family	#
3 m (male 5 pin - male 5 pin)	SCK-102-03-02
5 m Extension (male 5 pin - female 5 pin)	SCK-102-05-12

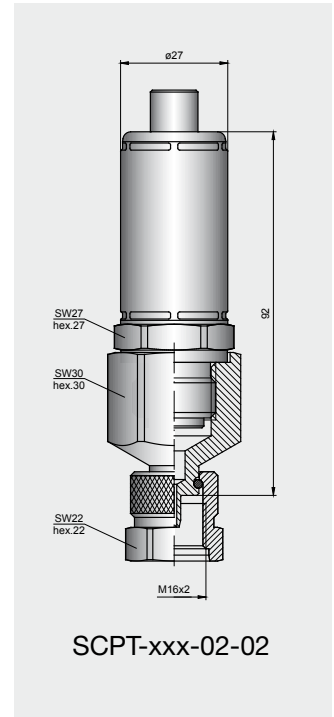

#	SCPT-015	SCPT-060	SCPT-150	SCPT-400	SCPT-600	SCPT-1000
Measuring Range (bar)	-1...015	0...060	0...150	0...400	0...600	0...1.000
Overload Pressure P_{max} (bar)	30	120	300	800	1.200	1.200
Burst Pressure (bar)	150	500	900	1.200	1.800	2.500
Temperature Measuring Range (°C) Accuracy ($\pm 1,5$ %) FS	-25...+105	-25...+105	-25...+105	-25...+105	-25...+105	-25...+105

FS = Full Scale Range

Accuracy	typ. $\pm 0,25$ % max. $\pm 0,5$ % + 0,2 %/year
Response Time (ms)	1
Electrical connection	5 pin connector
Pressure Port	1/2" BSPP
Housing	Stainless Steel 1.4301
Weight (g)	200

Seal	FKM
Ambient Temperature Range (°C)	-25...+80
Storage Temperature Range (°C)	-20...+80
T_{max} Fluid (°C)	+105
Reliability Cycles (10^6)	100
Shock Load	IEC 68-2-29

- Robust stainless steel design
- Response times of 1 ms
- Capturing of pressure peaks
- State-of-the-art CAN bus technology
- Simple wiring with SPEEDCON®
- Long cable lengths up to 100 m
- Sensor identification LED (SIL)



All the advantages of the analog SCPT sensors are combined with state-of-the-art CAN bus technology. Simple wiring with up to 8 sensors on one bus cable and the SPEEDCON® quick-plug screw connection. Plug & Play functionality without much configuration efforts.

All pressure sensors are delivered with a diagnosis adapter (M16x2) installed. Connection to the hydraulic system takes place quickly and safely. Times for installation are reduced.

Pressure measurements	
-1... 016 bar	Pneumatics/ low pressure
0 ... 060 bar	Medium pressure
0 ... 160 bar	Medium pressure
0 ... 400 bar	Operating pressure hydraulics
0 ... 600 bar	High pressure
0 ... 1.000 bar	High pressure peaks
Temperature measurements	
-25...+105 °C	Oil temperature

SPEEDCON® is a registered trademark of PHOENIX CONTACT GmbH & Co. KG

SCPT Pressure/Temperature Sensor CAN 1/2" BSPP male incl. Adapter SCA-1/2-EMA-3	#
-1...016 bar/0...060 bar/0...160 bar/ 0...400 bar/0...600 bar/0...1.000 bar	SCPT-xxx-C2-05

SCPT Pressure/Temperature Sensor 1/2" BSPP male incl. Adapter SCA-1/2-PQC	#
-1...016 bar/0...060 bar/0...160 bar/ 0...400 bar/0...600 bar	SCPT-xxx-C2-05-PQC

SCK Connection cable CAN The Parker Service Master <i>Plus</i>	#
2 m	SCK-401-02-4F-4M
5 m	SCK-401-05-4F-4M
10 m	SCK-401-10-4F-4M

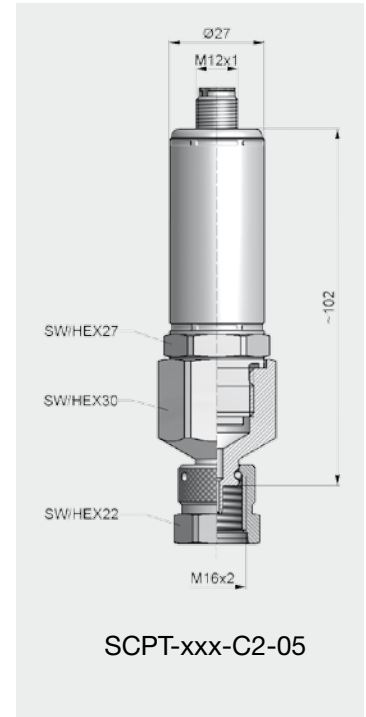

#	SCPT-016	SCPT-060	SCPT-160	SCPT-400	SCPT-600	SCPT-1000
Measuring Range (bar)	-1...016	0...060	0...160	0...400	0...600	0...1.000
Overload Pressure P _{max} (bar)	32	120	320	800	1.200	1.200
Burst Pressure (bar)	150	500	900	1.200	1.800	2.500
Temperature Measuring Range (°C) Accuracy ±2K typ./±3K max.	-25...+105	-25...+105	-25...+105	-25...+105	-25...+105	-25...+105

Accuracy	typ. ±0,25 % max. ±0,5 % + 0,2 %/year
Response Time (ms)	1
Electrical connection	5 pin, M12x1, connector
Pressure Port	1/2" BSPP
Housing	Stainless Steel 1.4301
Weight (g)	200
Seal	FKM

Ambient Temperature Range (°C)	-25...+85
Storage Temperature Range (°C)	-25...+85
T _{max} Fluid (°C)	+105
Reliability Cycles (10 ⁶)	100
Shock Load	IEC 68-2-29
Vibration Resistance	IEC 68-2-6 10...500 Hz

10 Temperature Measurement SCT

- High pressure-proof temperature sensor for hydraulic measurements
- Measurement of oil temperatures up to 125 °C
- Flexible operation
- Screw-in or manual sensor



In hydraulics, temperature measurements serve to locate faults and avoid the kind of damage caused by excessive oil temperatures in critical parts such as pumps and proportional valves.

To get the exact temperature, the measurement is done directly in the tube or hose line.

The screw-in sensors SCT-150 are compatible with flow measurement turbines SCFT-xxx-02-02.

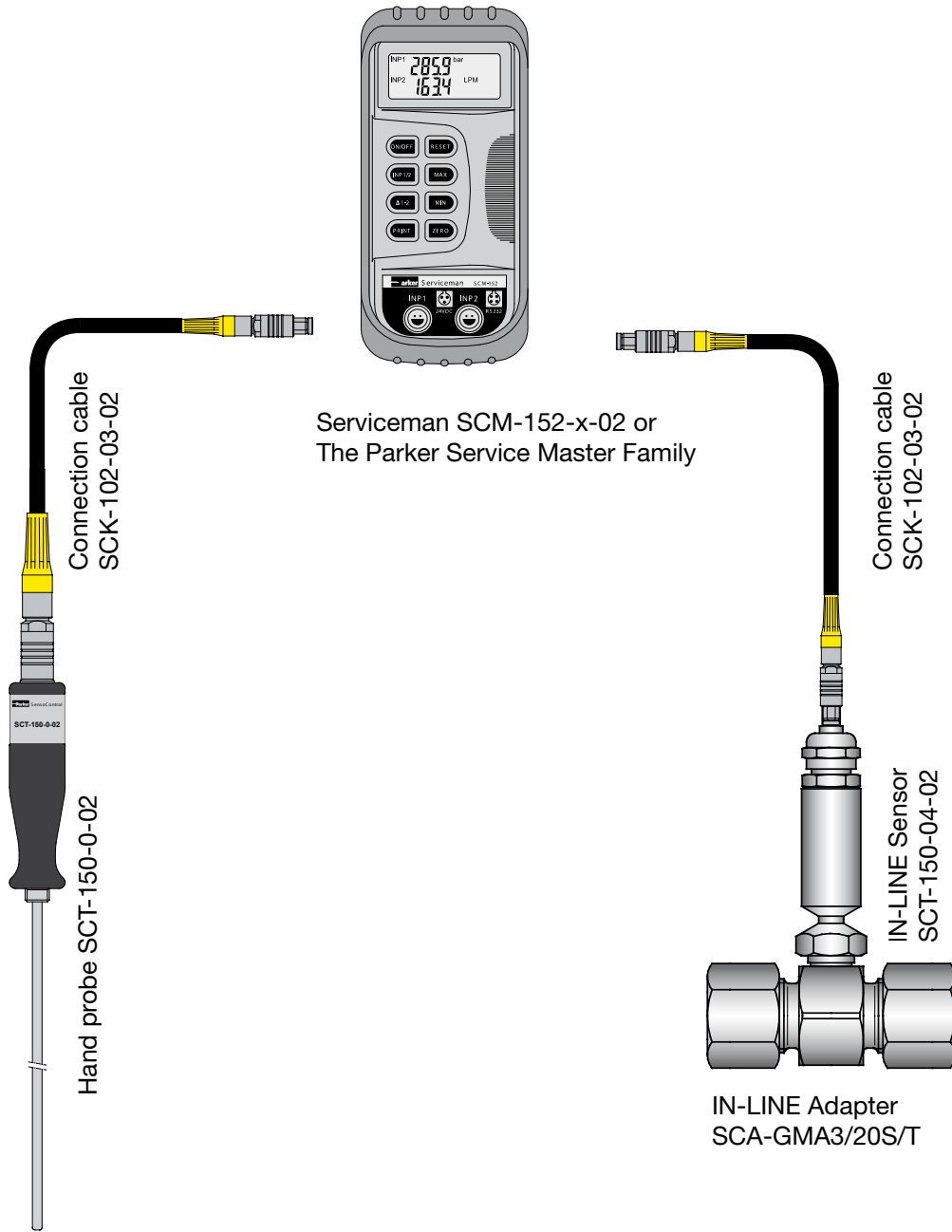

SCT-150 (-25°C...+125°C)

Oil temperatures in tanks and containers are measured with the help of hand probe SCT-150-0-02

The temperature sensor SCT-150-04-02 can be adapted to the hydraulic system up to a system pressure of 630 bar. The male stud is compatible with the test points of the GMA3/20 series and with flow turbine SCFT-xxx.

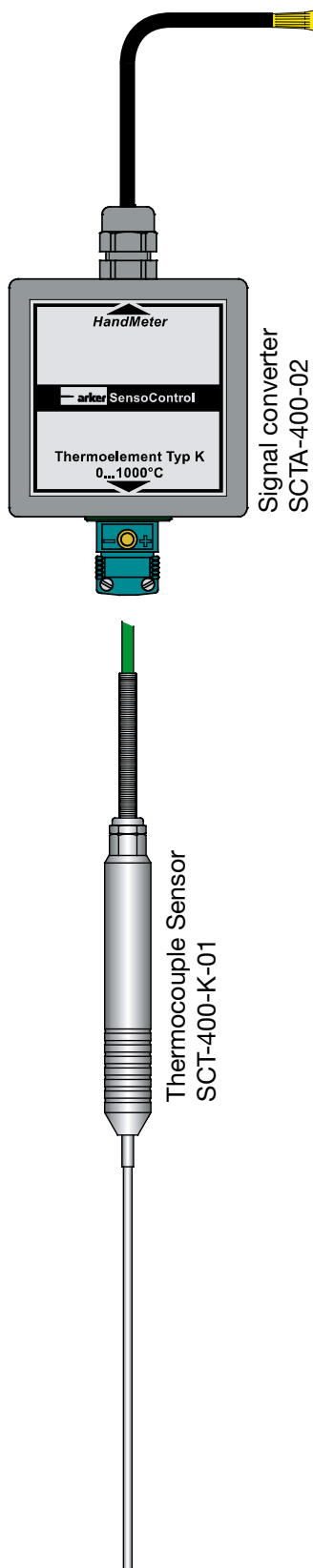

The Parker Service Master *Plus*
or The Parker Service Master *Easy*

SCT-400-K-01 with signal converter SCTA-400-02

High temperature-proof thermocouple-sensors are used for the measurement of exhaust-gas temperatures up to 1,000 °C in diesel engines.

The converter SCTA-400 is compatible with all thermocouple-sensors of the model K.

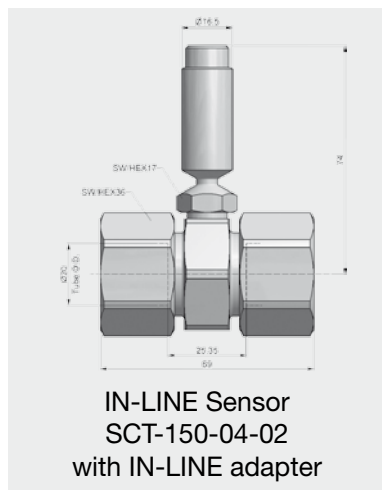

IN-LINE Sensor
SCT-150-04-02
with IN-LINE adapter

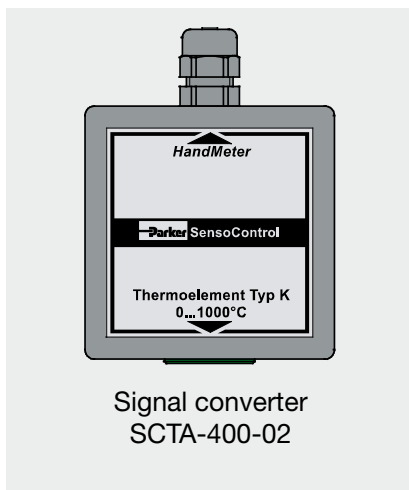

Signal converter
SCTA-400-02

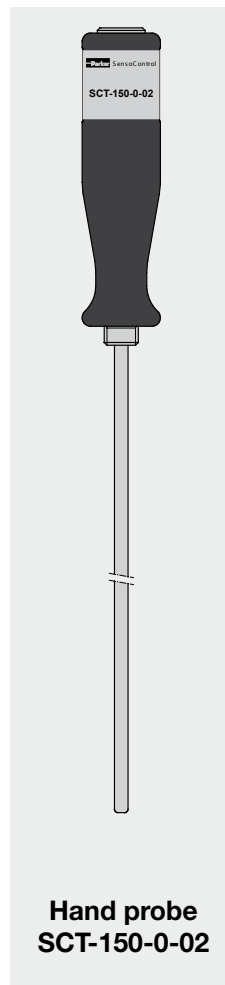

Hand probe
SCT-150-0-02

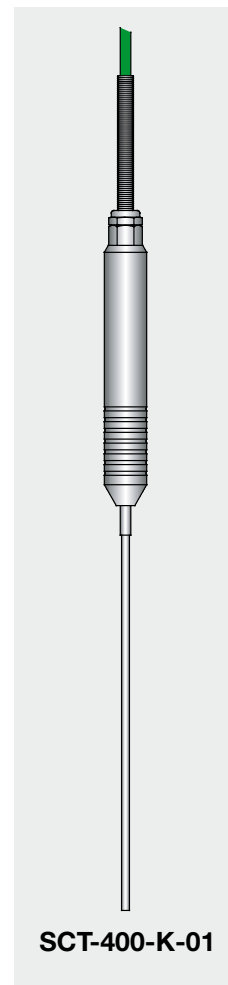

SCT-400-K-01

SCT Temperature Sensor ($T_{max} = 125\text{ }^{\circ}\text{C}$)	#
IN-LINE Sensor (M10x1) with female Connector (5 pin)	SCT-150-04-02
Hand Probe with female Connector (5 pin)	SCT-150-0-02
IN-LINE Adapter Tube assembly $\varnothing 20$ (M10x1)	SCA-GMA3/20S/T

SCT Temperature Sensor ($T_{max} = 1.000\text{ }^{\circ}\text{C}$)	#
Converter Thermocouple 1000°C	SCTA-400-02
Thermocouple Sensor	SCT-400-K-01

SCK Connection Cables	#
Serviceman/The Parker Service Master Family	
3 m (male 5 pin - male 5 pin)	SCK-102-03-02
5 m Extension cable (male 5 pin - female 5 pin)	SCK-102-05-12

	SCT-150-04-02	SCT-150-0-02	SCT-400-K-01	SCTA-400-02
Measuring Range ($^{\circ}\text{C}$)	-25...+125	-25...+125	0...+1.000	0...+1.000
Accuracy	$\pm 1,5\text{ }^{\circ}\text{C}$	$\pm 1,5\text{ }^{\circ}\text{C}$	$\pm 1,5\text{ }^{\circ}\text{C}$	$\pm 1,0\text{ \% FS}$
Response Time $T_{0,9}$ (sec.)	13,5	9,1	≤ 5	-
Ambient Temperature ($^{\circ}\text{C}$)	-25...+70	-25...+70	-20...+150	0...+50
Storage Temperature ($^{\circ}\text{C}$)	-25...+80	-25...+80	-20...+80	-25...+60
Operating Pressure (bar)	630	-	-	-
P_{max} (bar)	800	-	-	-
Burst Pressure (bar)	1.200	-	-	-
Housing	Steel C15K galvanized	Probe: Stainless Steel 1.4304 Grip: Delrin	Stainless Steel with 2 m fixed cable	ABS with 30 cm fixed cable
Seal	FKM	-	-	-
Weight (g)	100	120	150	-
Parts in Contact with Media	Steel C15K galvanized, FKM	Stainless Steel 1.4304	Stainless Steel	-

FS = FullScale

SCT Temperature Sensor ($T_{max} = 1.000\text{ }^{\circ}\text{C}$) not for Serviceman

- Contactless measurement of rotational speed
- Measurement of rotational speed up to 10,000 rpm
- With fixed cable 2 m



Rotational speed-dependent data, such as delivery from a variable pump, are determined ideally in combination with the pressure and flow-test of a hydraulic drive.

Contactless measurement (opto-electronic principal) can be done quickly and easily.

Rotational speed is detected, for example, at a main drive shaft (e. g. power take-off shaft of a tractor), and displayed on the hand-held device. Installation or adjustment is not necessary.

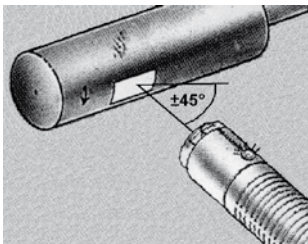

Rotating shaft - non-contact measurement of rotational speed.

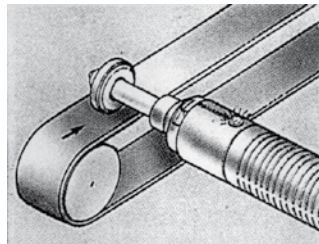

Contact measurement of rotational speed with the contact adapter

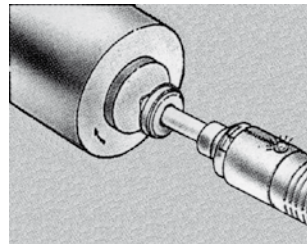

Front face measurement of rotational speed with contact adapter.

For accurate acquisition of the opto-electronic signal, please use the supplied reflecting strips.

For a shaft or belt, the rotational speed is measured directly with the contact adapter.



The Parker Service Master *Plus*
or The Parker Service Master *Easy*

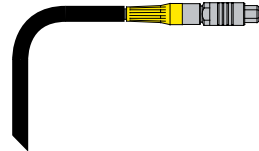
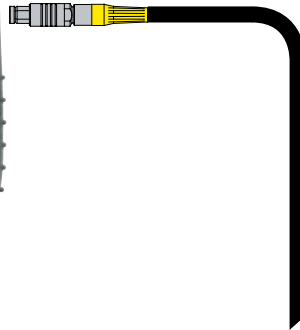

Serviceman
SCM-152-x-02

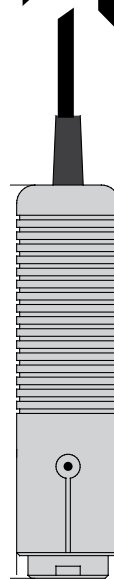

Tachometer SCRPM-220

Technical Data	
Input	
Measuring distance	25...500 mm
Measuring angle	± 45°
Type of measuring	optical, red LED
Output	
Measuring range	20...10.000 RPM
Accuracy	< 0.5 % FS
Resolution	± 5 RPM
Electrical connection	
Fixed cable 3 m	5 pin push-pull/4 pin
Ambient temperature	0...70 °C
General	
Material	ABS
Dimensions	∅ 34 mm/L = 130 mm
Weight	230 g

FS = FullScale

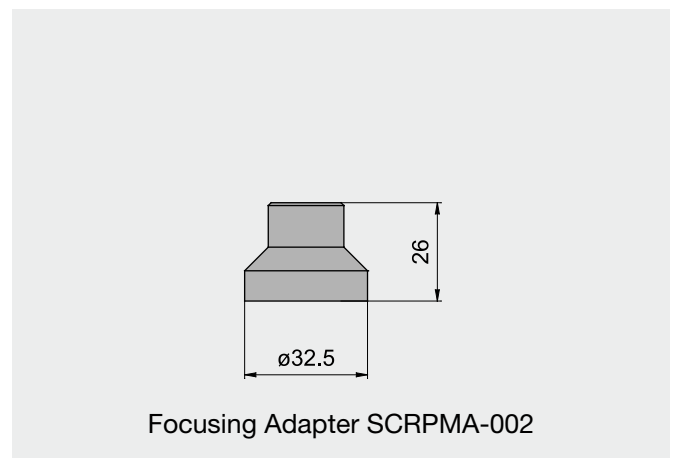
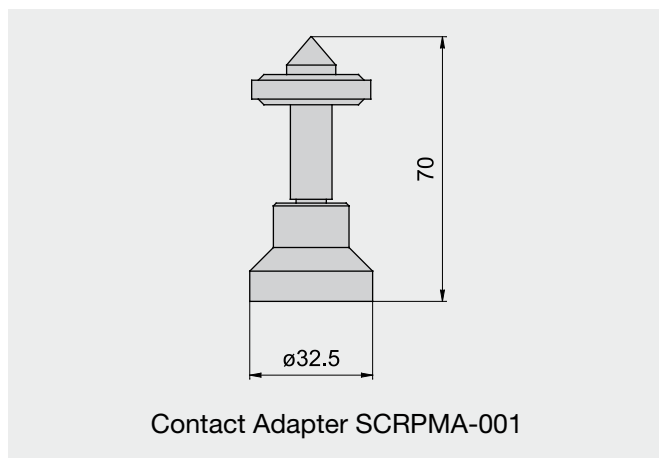
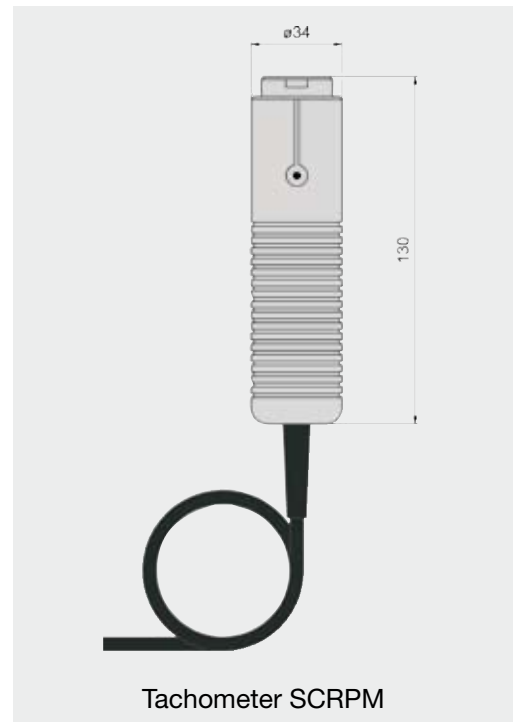

SCRPM Tachometer	
20...10.000 RPM	SCRPM-220
Contact Adapter	SCRPMMA-001
Focusing Adapter	SCRPMMA-002

Volume Flow Measurement

Depending on the measurement job to be done, various measuring instruments are available to the hydraulic technician:

1 Turbine flow meter type SCFT

- Very low flow resistance
- Built-in measurement points for pressure and temperature
- Very simple installation into a hydraulic system
- 6 different measuring ranges up to 750 l/min.
- Recording of a p/Q characteristic curve with a load valve to determine hydraulic performance

2 Hydraulik tester type SCLV





- High-pressure resistance up to 480 bar
- 2 Measuring ranges up to 750 l/min
- Integrated overload protection
- Reverse-mode operations

3 Flow meter type SCQ

- Flow measurement with direction indication
- Very fast reaction time < 2 ms
- Wide viscosity range
- Screw-in cartridge in connector block SCAQ



In addition to pressure measurement, the precise determination of flow volume in hydraulic equipment gives important evidence of the condition of the hydraulics. The efficiency of hydraulic drives such as hydrostatic units or variable pumps depends on the amount of flow. Hydraulic performance is determined by pressure and flow. The degree of wear in a hydraulic drive can be ascertained by comparing nominal and actual values. The resulting measurements can be used, for example, in preventive maintenance for systematic servicing and cost reductions. In mobile hydraulics, the efficiency of the machine is continually checked and documented. The diagnosis of pressure and flow thereby gives a total analysis.

	SCFT Turbine Flow Meter	SCFT-CAN Turbine Flow Meter	SCLV Hydraulic Tester	SCQ Flow Meter
Intended use				
	<ul style="list-style-type: none"> ✓ Low-loss flow measurement 	<ul style="list-style-type: none"> ✓ Low-loss flow measurement 	<ul style="list-style-type: none"> ✓ Hydraulic tester 	<ul style="list-style-type: none"> ✓ For quick flow changes ✓ Measures in both directions
	<ul style="list-style-type: none"> ✓ Response time ≤ 50 ms ✓ Various measurement ranges ✓ Low flow resistance ✓ Up to 750 l/min ✓ Up to 420 bar ✓ Reverse-mode operations 	<ul style="list-style-type: none"> ✓ Response time ≤ 50 ms ✓ Various measurement ranges ✓ Low flow resistance ✓ Up to 750 l/min ✓ Up to 420 bar ✓ Reverse-mode operations ✓ CAN bus connection 	<ul style="list-style-type: none"> ✓ Response time ≤ 50 ms ✓ Various measurement ranges ✓ Low flow resistance ✓ Up to 750 l/min ✓ Up to 420 bar ✓ With integrated PQ measurement ✓ Load valve ✓ Overload protection 	<ul style="list-style-type: none"> ✓ Response time ≤ 2 ms ✓ Reverse-mode operations ✓ Wide range of viscosities ✓ Compact size ✓ Up to 420 bar
Measuring range	1,0...15/3...60/5...150/ 8...300/15...600/ 20...750 l/min		10...300/20...750 l/min	-60 ...+60 l/min -150...+150 l/min
Ports	1/2"...1 1/4" BSPP		1/2"...1" BSPP	M24/M42 Cartridge Block SCAQ-XXX
Measuring process	Turbine		Turbine	Spring/piston principle
Accuracy	< ±1 % FS Response time ≤ 50 ms		< ±1 % FS Response time ≤ 50 ms	< ±2 % FS Response time ≤ 2 ms
Applications	Test bench, general machinery construction and hydraulic installation construction			
				
Order code	SCFT-xxx-02-02	SCFT-xxx-C2-05	SCLV-PTQ-xxx	SCQ-xxx-0-02
Refer to page	52-55	56-59	60-63	64-68

- **Measurement principle:**
flow turbine
- **6 flow ranges up to 750 l/min**
- **Simple installation**
- **Resistant to high pressure**
up to 480 bar
- **Low flow resistance**
- **Built-in pressure and temperature measurement points**
- **Suitable for reverse operation**



Flow measurement with low flow resistance combined p/T/Q measurement

Function

A turbine wheel is driven by the oil flow. The frequencies thus produced are processed by digital electronics. The influence of turbulent flow effects is compensated for. Because of the low flow resistance Q_R the hydraulic circuit operates with very low losses.

For pressure measurement the turbine is equipped with an EMA-3 test point.

Oil temperatures are measured direct in the oil flow. Consequently all the important measurement parameters are available at one measuring location.

Applications

- mobile diagnosis
- p-Q measurement in construction and agricultural machines
- hydraulic tests with load valves
- automatic scaling

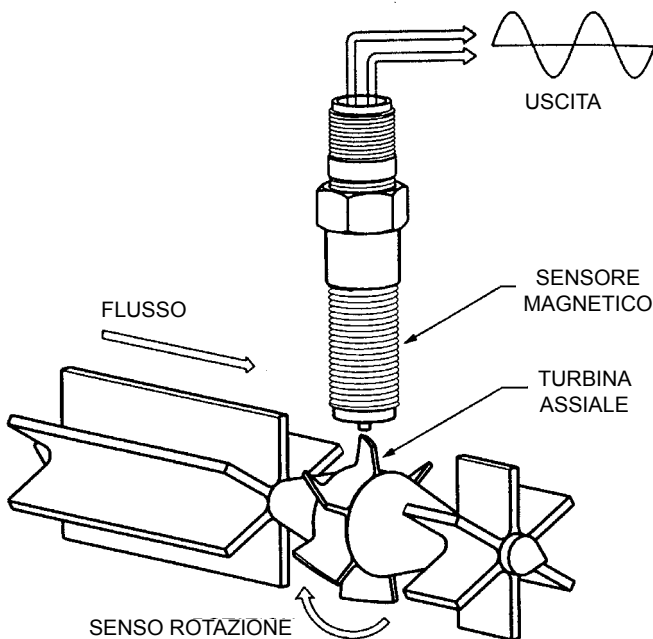

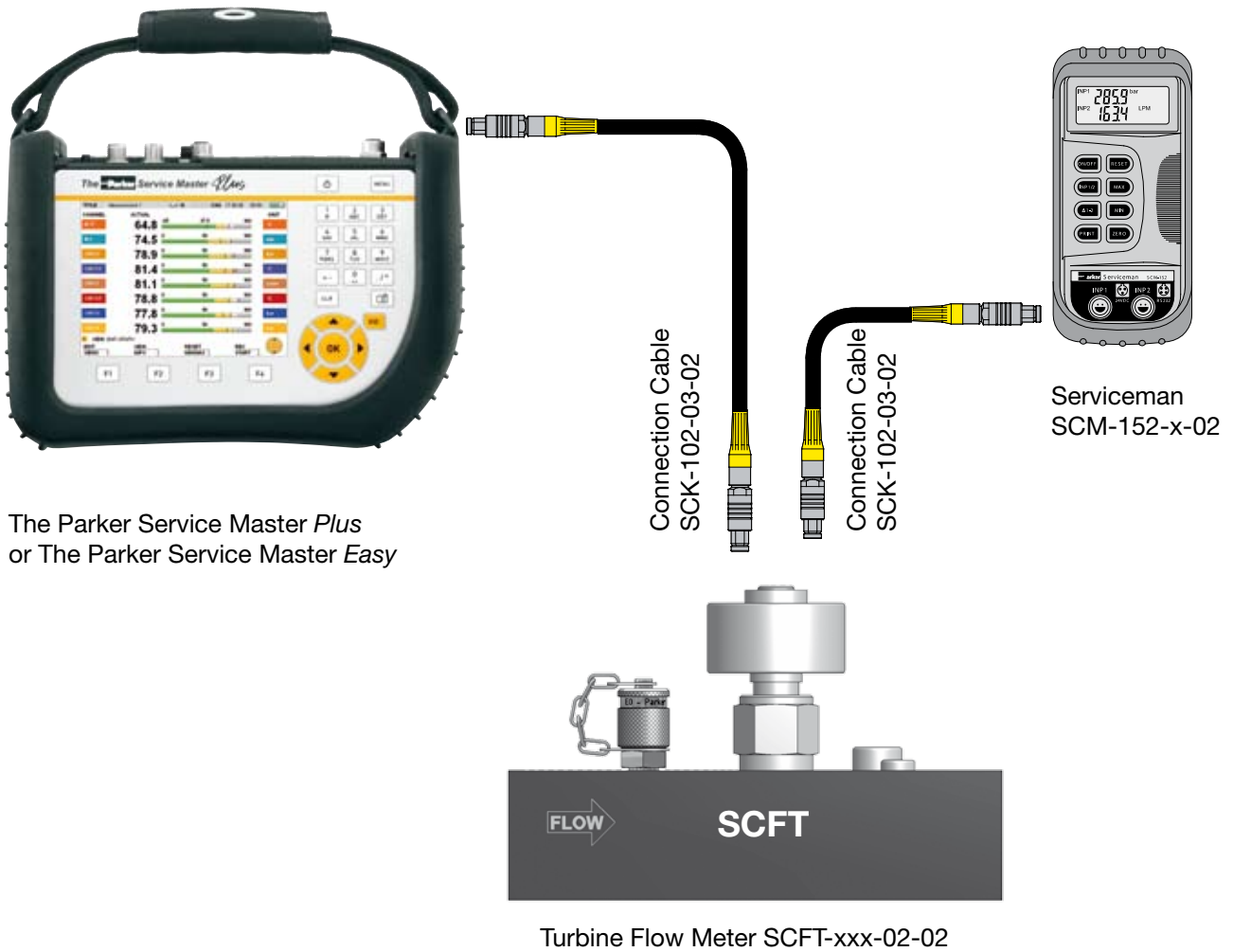

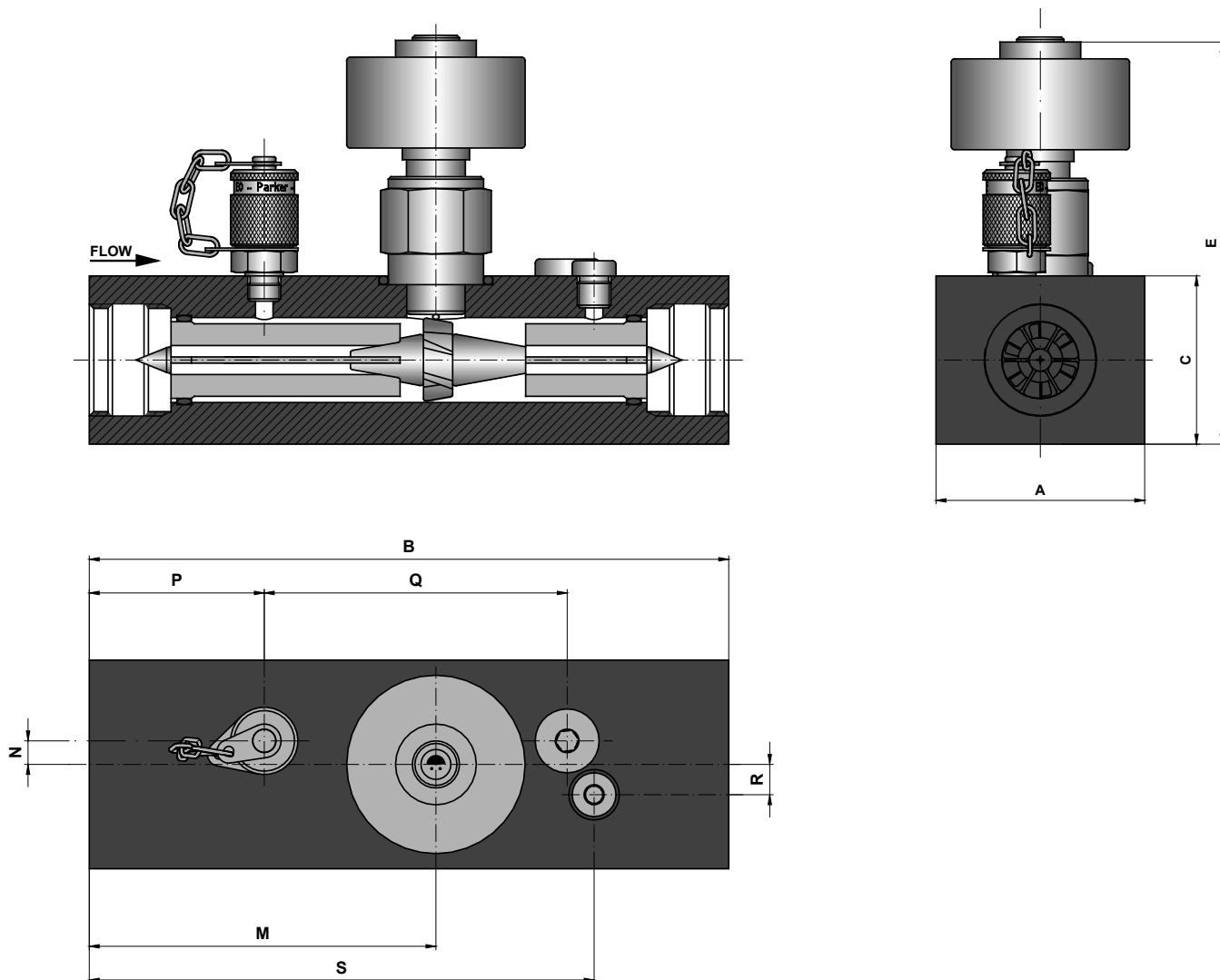

#	SCFT-015	SCFT-060	SCFT-150	SCFT-300	SCFT-600	SCFT-750
A	37	62	62	62	62	100
B	136	190	190	190	212	212
C	37	50	50	50	75	75
E	117	130	130	134	150	154
M	70	103	103	103	127	126
N	0	5	5	7	9	10
P	25	50	50	52	62	60
Q	N/A	92	92	90	106	104
R	0	5	5	9	11	10
S	115	157	157	150	168	181

#	SCFT-015	SCFT-060	SCFT-150	SCFT-300	SCFT-600	SCFT-750
Flow Range QN (l/min)	1...015	3...060	5...150	8...300	15...600	20...750
Accuracy (± %) FS/IR @ 21cSt.	1,0 FS	1,0 IR*	1,0 IR*	1,0 IR*	1,0 IR*	1,0 IR*
Operating Pressure PN (bar)	350	350	350	350	290	400
Ports (A - B)	1/2" BSPP	3/4" BSPP	3/4" BSPP	1" BSPP	1-1/4" BSPP	1-7/8" UNF
Pressure Drop ΔP_{max} (bar) @ FS, 21cSt	1,5	1,5	1,5	4	5	5
Weight (g)	650	750	750	1200	1800	2100

FS = FullScale

IR = Indicated Reading

* = for measurements ≥ 15 % FS, for measurements < 15 % FS accuracy 0.15 % FS

Response Time (ms)	50
Q_{max} (l/min)	QN x 1,1
Overload Pressure P_{max} (bar)	PN x 1,2
Ports: Temperature Port (SCT-150) Pressure Port (EMA3 Fitting) Pressure Port (VSTI)	M10x1 OR M16x2 1/4" BSPP
Housing	Aluminium
Sealing	FKM
Parts in Contact with Media	Aluminium, Steel, FKM

Ambient Temperature (°C)	-10...+50
Storage Temperature (°C)	-20...+80
T Fluid (°C)	-20...+90
Filtration (µm)	25 (10 µm for SCFT-015)
Viscosity Range (cSt.)*	10...100

* (calibrated at 21 cSt, other viscosities on request)

SCFT Turbine Flow Meter	#
1,0...15/3...60/5...150/8...300/15...600/20...750 l/min	SCFT-xxx-02-02

SCK Connection Cables	#
Serviceman/The Parker Service Master <i>Family</i>	
3 m (male 5 pin - male 5 pin)	SCK-102-03-02
5 m (male 5 pin - male 5 pin)	SCK-102-05-02
5 m Extension cable (male 5 pin - female 5 pin)	SCK-102-05-12

- Flow turbine with CAN bus technology
- 6 flow ranges up to 750 l/min
- Simple installation
- Resistant to high pressure up to 480 bar
- Low flow resistance
- Built-in pressure and temperature measurement points
- Suitable for reverse operation
- Simple wiring with SPEEDCON®
- Long cable lengths up to 100 m

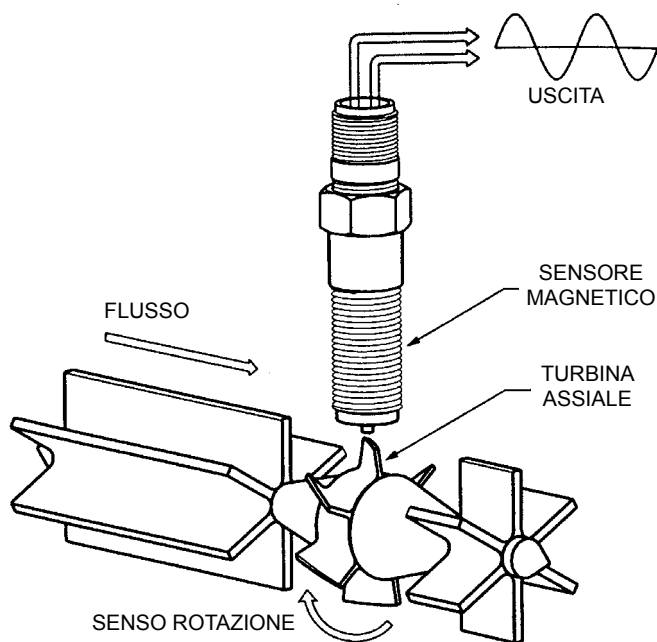

Flow measurement with low flow resistance combined p/T/Q measurement

Function

A turbine wheel is driven by the oil flow. The frequencies thus produced are processed by digital electronics. The influence of turbulent flow effects is compensated for. Because of the low flow resistance Q_R the hydraulic circuit operates with very low losses.

For pressure measurement the turbine is equipped with an EMA-3 test point.

Oil temperatures are measured direct in the oil flow. Consequently all the important measurement parameters are available at one measuring location.

Applications

- mobile diagnosis with **The Parker Service Master Plus**
 - p-Q measurement in construction and agricultural machines
 - hydraulic tests with load valves
 - automatic scaling

SPEEDCON® is a registered trademark of the PHOENIX CONTACT GmbH & Co. KG



The Parker Service Master *Plus*
or The Parker Service Master *Easy*

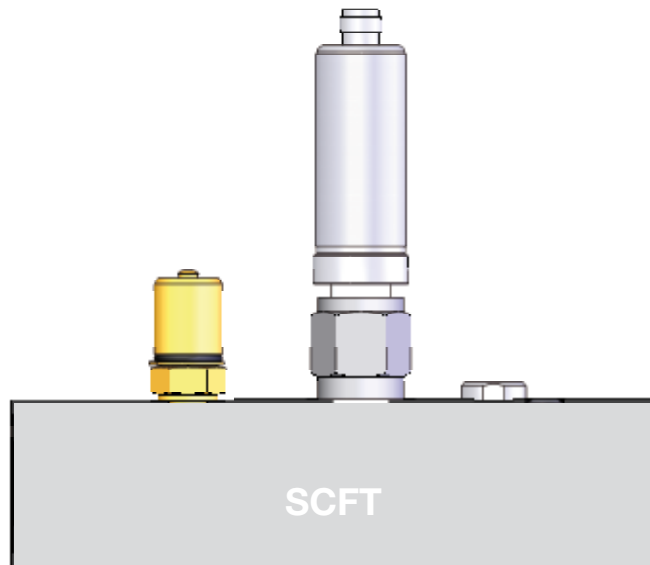

Turbine SCFT-xxx-C2-05

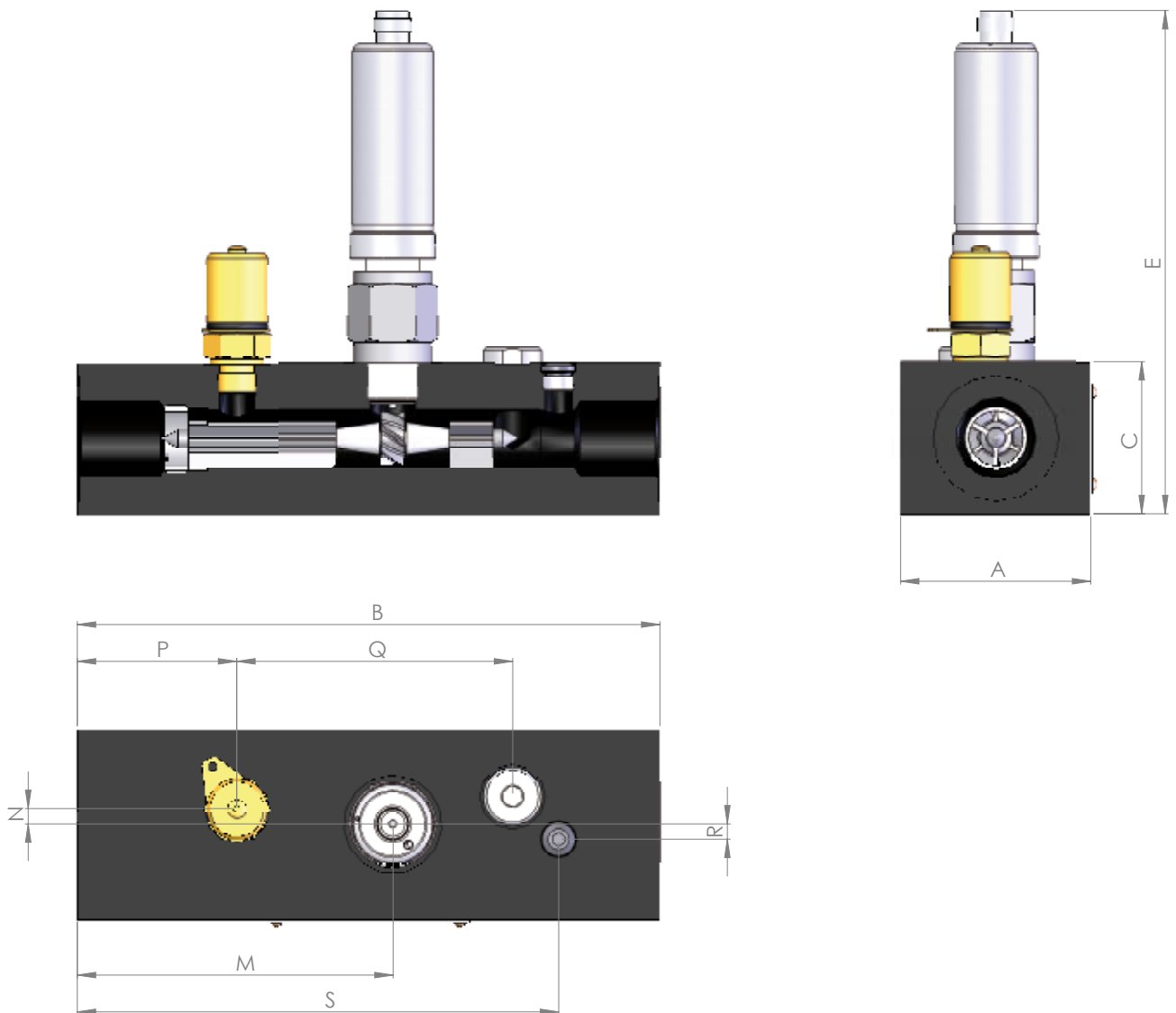

SCFT-CAN -#	015	060	150	300	600	750
A	36,9	62	62	62	62	100
B	136	190	190	190	212	212
C	36,9	49,6	49,6	49,6	75	75
E	150	164	164	168	183	186
M	69,5	103	103	103	127	125,8
N	0	5	5	7	9	12
P	25	52	52	52	62	60
Q	/	90	90	90	106	104
R	0	5	5	9	11	10
S	115	157	157	152	168	181

SCFT-CAN -#	015	060	150	300	600	750
Flow Range QN (l/min)	1...015	3...060	5...150	8...300	15...600	20...750
Accuracy (± %) FS/IR @ 21cSt.	1,0 FS	1,0 IR*	1,0 IR*	1,0 IR*	1,0 IR*	1,0 IR*
Operating Pressure PN (bar)	350	350	350	350	290	400
Ports (A - B)	1/2" BSPP	3/4" BSPP	3/4" BSPP	1" BSPP	1-1/4" BSPP	1-7/8" UNF
Pressure Drop ΔP_{max} (bar) @ FS, 21cSt	1,5	1,5	1,5	4	5	5
Weight (g)	650	750	750	1200	1800	2100

FS = FullScale

IR = Indicated Reading

* = for measurements ≥ 15 % FS, for measurements < 15 % FS accuracy 0.15 % FS

Response Time (ms)	50
Q_{max} (l/min)	QN x 1,1
Overload Pressure P_{max} (bar)	PN x 1,2
Ports: Temperature Port (SCT-150) Pressure Port (EMA3 Fitting) Pressure Port (VSTI)	M10x1 OR M16x2 1/4" BSPP
Housing	Aluminium
Sealing	FKM
Parts in Contact with Media	Aluminium, Steel, FKM

Ambient Temperature (°C)	-10...+50
Storage Temperature (°C)	-20...+80
T Fluid (°C)	-20...+90
Filtration (µm)	25 (10 µm for SCFT-CAN-015)
Viscosity Range (cSt.)*	10..100

* (calibrated at 21 cSt, other viscosities on request)

SCFT-CAN Turbine Flow Meter	#
1,0...15/3...60/5...150/8...300/15...600 l/min	SCFT-xxx-C2-05
20...750 l/min; P_{max} = 480 bar	SCFT-750-C2-05

SCK Connection Cables CAN	#
The Parker Service Master <i>Plus</i>	
2 m	SCK-401-02-4F-4M
5 m	SCK-401-05-4F-4M
10 m	SCK-401-10-4F-4M

- **Measurement principle:**
Measuring instrument for pressure, temperature and flow volume
- 2 measurement ranges up to 750 l/min
- Resistant to high pressure up to 480 bar
- Integrated overload protection
- Reverse-mode operations
(Direction of flow A - B)
- Also with CAN bus connection



Precise measurements of flow, pressure and temperature

Special features:

- Easy to use in both flow directions; integrated oil bypass protects the system, testing device and operator from surge pressures
- User-selectable flow direction enables smooth connections and simple measurements
- Can be put into use quickly with pumps, valves, motors, cylinders and hydrostatic drives

The hydraulic testers are designed for testing the functionality of motors, pumps, valves and hydrostatic drives. These hydraulic testers are easy to handle and capable of locating errors in a hydraulic system. This can help you in reducing outage times and performing preventative maintenance.

These hydraulic testers can be used for precisely measuring flow, pressure and temperature. The testers can also be helpful when performing hydraulic system maintenance, locating error sources on directional control valves and making valve adjustments.

The pressure-load valve with its integrated bypass-blow-out discs makes it possible to build up pressure progressively in order to check the flow in an entire working area.

Integrated safety shut-off (Blow-out discs)

The load valve is fitted with two safety blow-out discs. The device is protected by this safety mechanism. These discs will break and the load valve will become inactive whenever the maximum allowed operating pressure (P_{max}) is exceeded. The complete flow then runs off to the tank.

Read carefully through the operating manual before replacing the blow-out discs.

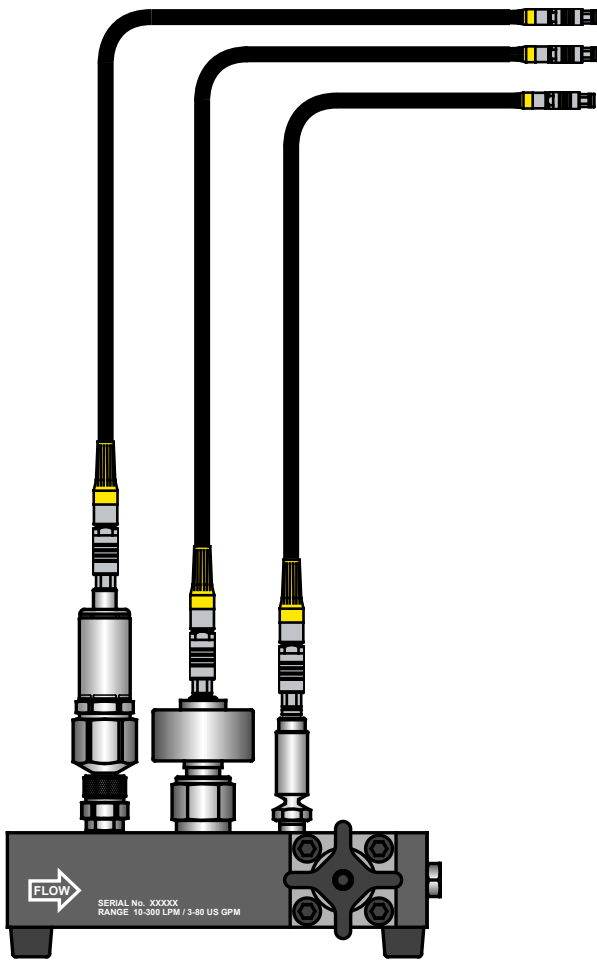

Measurement of pressure, flow and temperature using The Parker Service Master *Easy* or *Plus* and hydraulic-tester SCLV-PTQ

The p-Q diagram (to the right) shows the power determined. Especially in hydraulic pump (load sensing) systems the speed-dependent load is important to analyze. The evaluation in **SensoWin®** will be done quickly and simply.

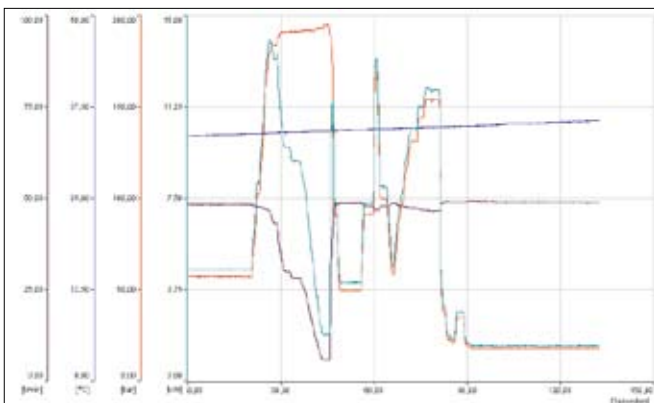
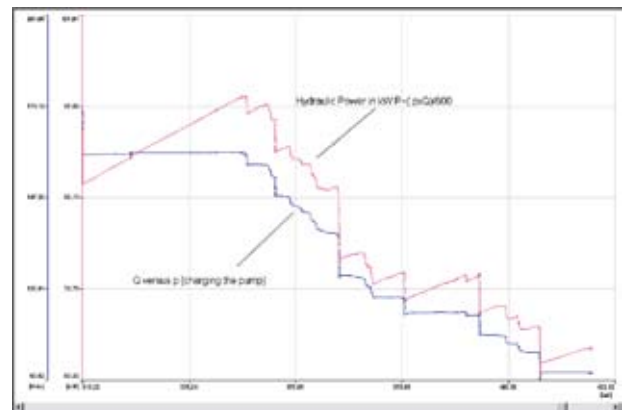

The hydraulic power of a system can be analyzed by a combined measurement of pressure and flow (to the left). The diagram shows an application with a hydraulic-tester SCLV-PTQ. Pressure in the system is generated by the integrated loading valve.

In the evaluation power will be calculated from the flow volume and pressure of the pump.

SCLV-PTQ-xxx

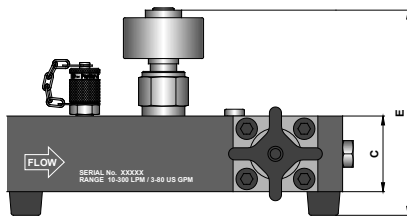

SCFT-150-DRV

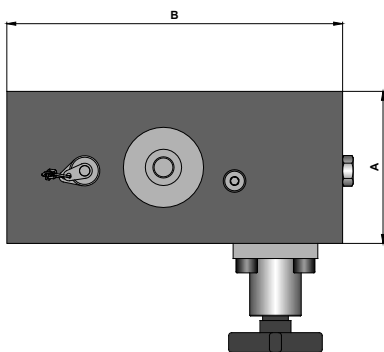
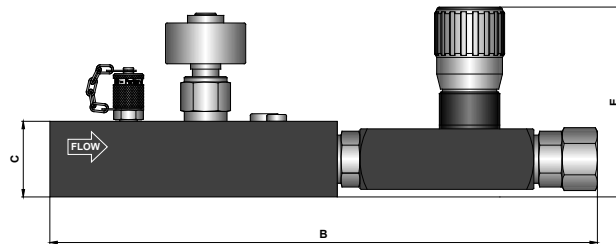

#	SCFT-150-DRV	SCLV-PTQ-300	SCLV-PTQ-750
A	62	98	117
B	370	222	235
C	50	50	75
E	130	135	150

#	SCFT-150-DRV	SCLV-PTQ-300	SCLV-PTQ-750
Accuracy QN (l/min)	6...150	10...300	20...750
Accuracy (± %) IR @ 21cSt.	1,0	1,0 (> 20 l/min)	1,0 (> 25 l/min)
Operating Pressure PN (bar)	350	350	400
Safety shut-off (Blow-out disc)	-	420 bar	480 bar
Ports (A - B)	3/4" BSPP	1" BSPP	1-7/8" UNF
Pressure Drop ΔP_{max} (bar) @ (FS) 21cSt.	15	4	5
Weight (kg)	4,2	5,5	8,9

FS = FullScale
IR = Indicated Reading

Response Time (ms)	50
Q_{max} (l/min)	QN x 1,1
Overload Pressure P_{max} (bar)	PN x 1,2
Ports: Temperature Port (SCT-150) Pressure Port (EMA3 Fitting) Pressure Port (VSTI)	M10x1 OR M16x2 1/4" BSPP
Housing	Aluminium
Sealing	FKM
Parts in Contact with Media	Aluminium, Steel, FKM

Ambient Temperature (°C)	-10...+50
Storage Temperature (°C)	-20...+80
T Fluid (°C)	-20...+90
Filtration (µm)	25
Viscosity Range (cSt.)*	10...100

* (calibrated at 21 cSt, other viscosities on request)

SCLV-PTQ Hydraulic Tester with Load Valve	#
10...300 l/min, $P_{max} = 420$ bar	SCLV-PTQ-300
10...300 l/min, $P_{max} = 420$ bar, with CAN bus connection	SCLV-PTQ-300-C2-05
20...750 l/min, $P_{max} = 480$ bar	SCLV-PTQ-750
20...750 l/min, $P_{max} = 480$ bar, with CAN bus connection	SCLV-PTQ-750-C2-05

SCLV-PTQ Safety Blow-Out Discs	#
10...300 l/min, $P_{max} = 420$ bar	SCLV-DISC-300
20...750 l/min, $P_{max} = 480$ bar	SCLV-DISC-800

SCFT Flow-Turbine incl. Pressure Control Valve with Non Return Protection	#
6...150 l/min; $P_{max} = 400$ bar	SCFT-150-DRV
6...150 l/min; $P_{max} = 400$ bar, with CAN bus connection	SCFT-150-DRV-C2-05

SCK Connection Cables Serviceman/The Parker Service Master <i>Family</i>	#
3 m (male 5 pin - male 5 pin)	SCK-102-03-02
5 m (male 5 pin - male 5 pin)	SCK-102-05-02
5 m Extension cable (male 5 pin - female 5 pin)	SCK-102-05-12

SCK Connection Cables CAN The Parker Service Master <i>Plus</i>	#
2 m	SCK-401-02-4F-4M
5 m	SCK-401-05-4F-4M
10 m	SCK-401-10-4F-4M

- Measurement principle: spring/piston system
- Flow measurement with direction indication
- Response time < 2 ms
- Compact design
- Withstands pressures up to 420 bar
- Wide range of viscosity
- p/T/Q measurement possible with connection block



Flow measurement with direction indication for mobile and stationary measurement jobs

Function

When there is a flow from A to B or B to A, the piston (K) is moved. When at rest, the spring (F) and piston (K) are in equilibrium. The stroke change (S) is proportional to the flow volume and is converted by the built-in electronics to a measured value. By the change in direction of the piston (B to A) flow directions can be shown (e.g. -45.8 l/min.). The response time of the piston movement is less than 0.002 s.

Application

In the field of high pressure hydraulics, the rapid capture of the amount of flow is of great significance. The reaction times of the SCQ's enable the dynamic behaviour of hydraulic systems to be measured. The indication of direction is helpful when searching for faults in hydraulic systems. Rapid load changes, which can cause damage for example in valves and pumps, can be determined. Installation with a connection block permits the combined measurement of p, T and Q. Rapid assembly of the SCQ's is achieved with an in-line adapter for tube or hose installation.

Robust design makes possible extreme condition applications, such as, for example, high load changes or rates of pressure increase.

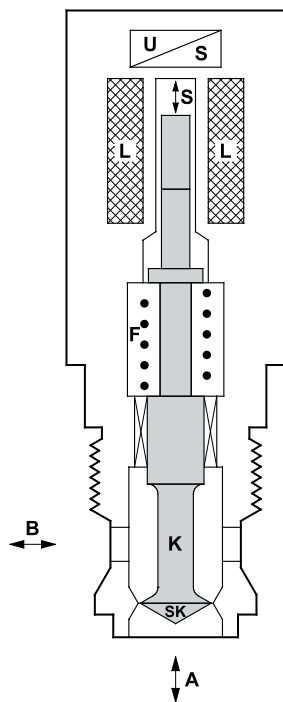

SCQ measurement principle



The Parker Service Master *Plus*
or The Parker Service Master *Easy*

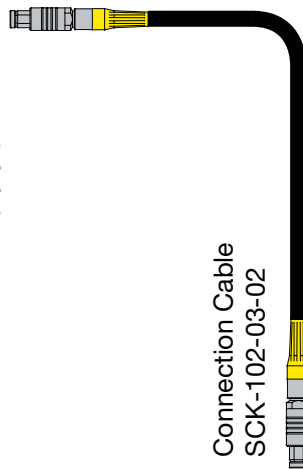

Connection Cable
SCK-102-03-02

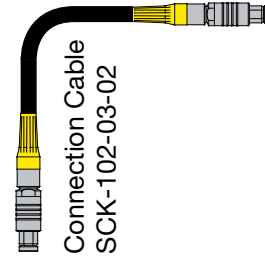

Connection Cable
SCK-102-03-02

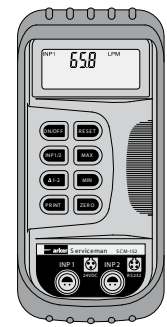

Serviceman
SCM-152-x-02

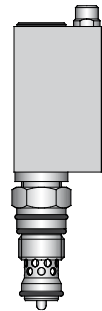

Flow Meter
SCQ-060-0-02

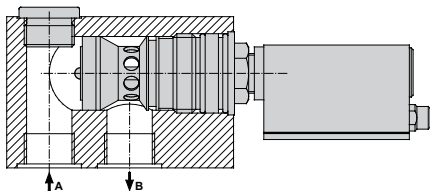

Flow Meter SCQ
in Connection Block SCAQ

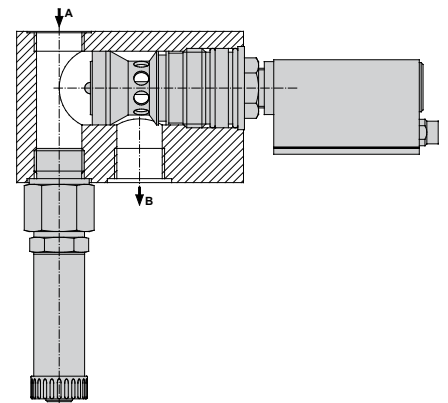

Flow Meter SCQ with
Temperature Sensor SCPT
in Connection Block SCAQ

Port dimensions and pressure drop graph SCQ-060

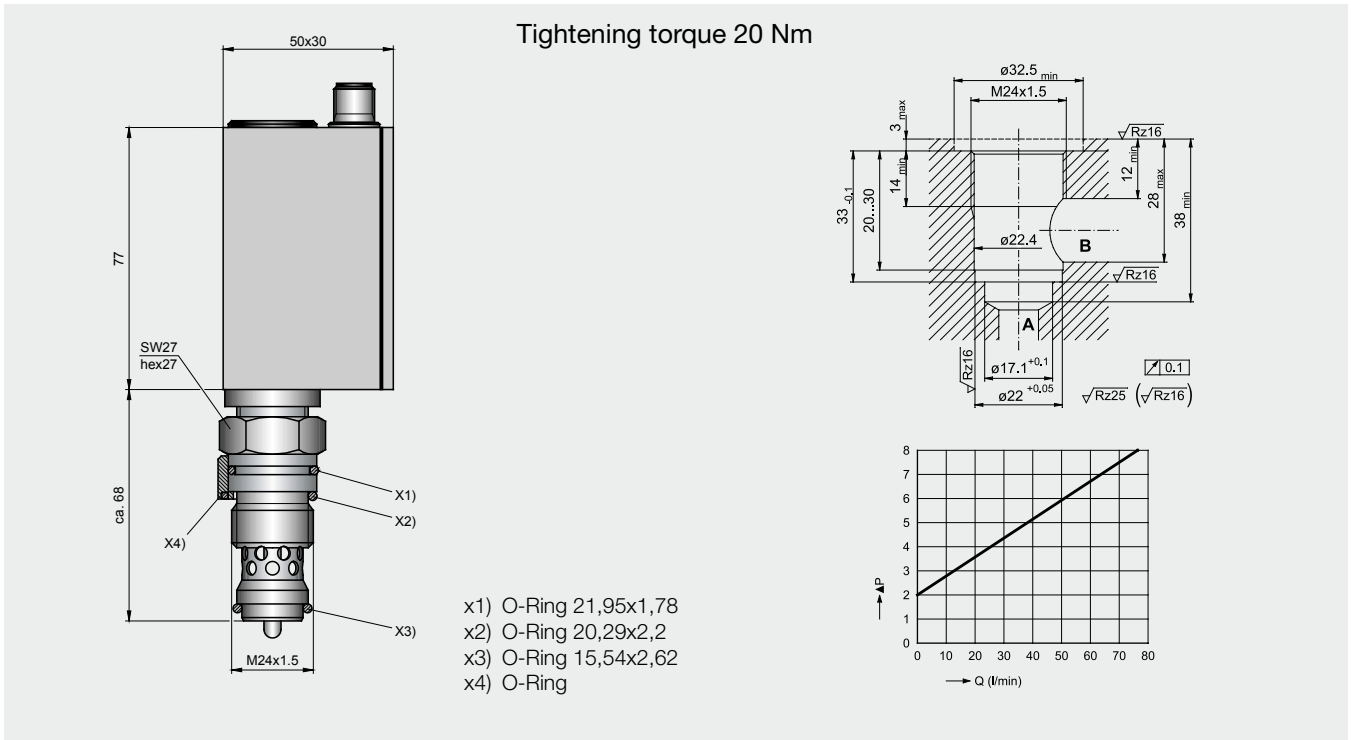

Port dimensions and pressure drop graph SCQ-150

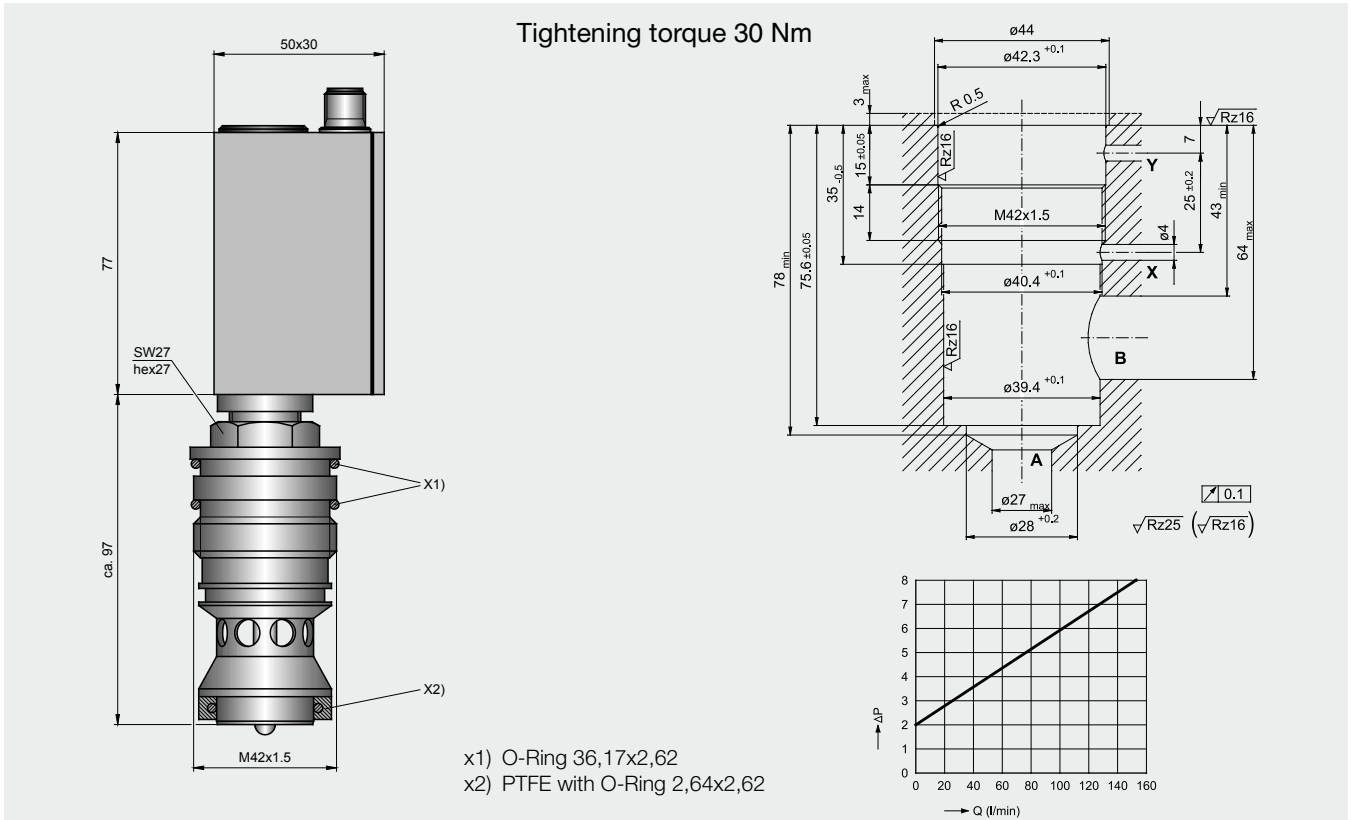

Connection Block SCAQ-060

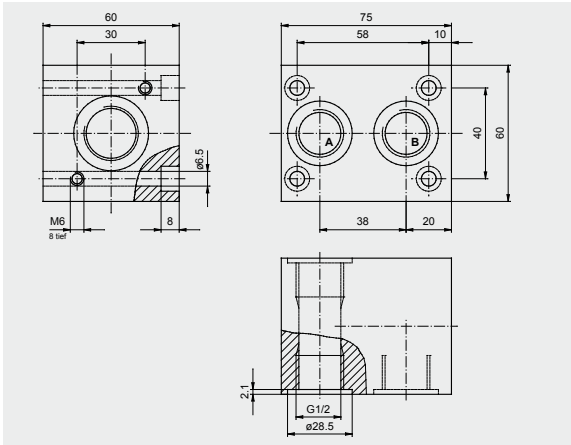

IN-LINE Adapter SCAQ-GIR1/2

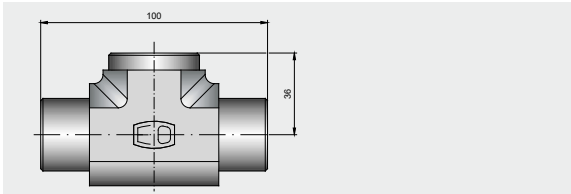

Connection Block SCAQ-150

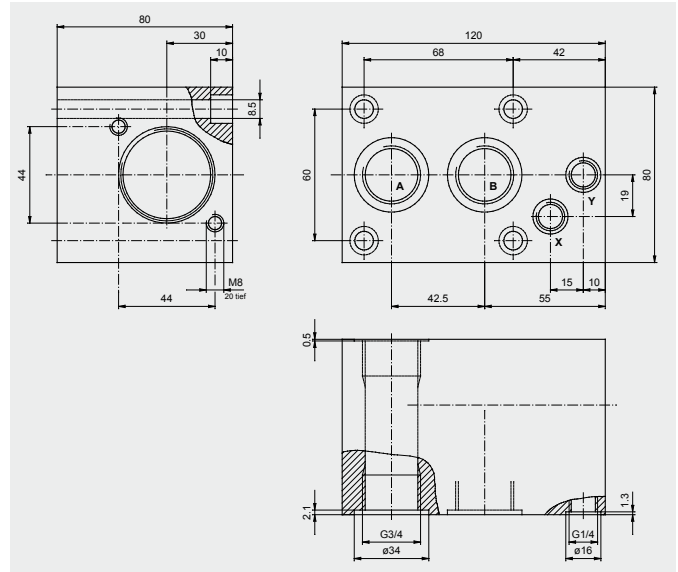

SCQ Flow Meter (0...±60 l/min)	#
0...60 l/min (incl. Distance ring)	SCQ-060-0-02
Distance ring (O-Ring SCQ-060)	SC-910
Seals for SCQ-060	SC-911

SCAQ IN-LINE Adapter (60 l/min)	#
1/2" BSPP female (A-B) und M24 female for SCQ-060	SCAQ-GIR1/2A4CX
with Screw Plugs:	
Cartridge Port M24 male (SCQ-060)	SCQ-M24X1.5-ED

SCAQ Block (60 l/min)	#
1/2" BSPP female (A-B) und M24 female for SCQ-060	SCAQ-060
with Screw Plugs:	
Cartridge Port M24 male (SCQ-060)	SCQ-M24X1.5-ED
1/2" BSPP male port (A-B)	SCQ-R1/2-ED

SCQ Flow Meter (0...±150 l/min)	#
0...150 l/min	SCQ-150-0-02
Seals for SCQ-150	SC-912

SCAQ Block (150 l/min)	#
3/4" BSPP female (A-B) und M42 female for SCQ-150	SCAQ-150
with Screw Plugs:	
Cartridge Port M24 male (SCQ-060)	SCQ-M42X1.5-ED
3/4" BSPP male port (A-B)	SCQ-R3/4-ED

	SCQ-060	SCQ-150
Flow Range Q_N	-60...+60 l/min	-150...+150 l/min
Q_{max}	-66...+66 l/min	-165...+165 l/min
Ports	M24 (NG10)	M42 (NG16)
Weight (g)	670	1.050

Accuracy	
Deviation from Characteristic Curve	±2 % FS @ 46cSt.
Response Time	2 ms
Thermal Drift	±0,05 % FS/°C
Repeat Accuracy	±0,5 % FS
Resistance to Pressure	
Pressure Range	3...420 bar
Operating Pressure P_N	315 bar
Overload Pressure P_{max}	420 bar
Pressure Drop ΔP (bar) @ (FS)	see diagram
Material	
Housing	Steel
Sealing	NBR
Parts in Contact with Media	Steel, NBR

Ambient Conditions	
Operating Temperature	+10...+60 °C
Storage Temperature	-20...80 °C
T_{max} Fluid (°C)	+80 °C
Filtration	25 µm
Viscosity Range	15...100 cSt.
Protection	IP54 DIN EN 60529
Electrical Connection to Hand-Held Measuring Instrument	
Plug connection	5-pin, push-pull
Power Supply	+7...+15 VDC
Output	±3 VDC
Electromagnetic Compatibility	
Interference Emissions	EN 61000-6-3
Interference Resistance	EN 61000-6-2

FS = FullScale

SCK Connection Cables	#
Serviceman/The Parker Service Master <i>Family</i>	
3 m (male 5 pin - male 5 pin)	SCK-102-03-02
5 m (male 5 pin - male 5 pin)	SCK-102-05-02
5 m Extension cable (male 5 pin - female 5 pin)	SCK-102-05-12

- **Compact size**
- **Interference-free**
- **Compatible with all diagnostic sensors and diagnostic measuring instruments**
- **Push-Pull plug**
- **Various lengths available**
- **Oil-resistant material**

Cable for CAN bus sensors

Parker CAN bus cables are used to connect Parker CAN bus sensors to the **The Parker Service Master Plus** SCM-500.

The quick-plug screw connection SPEEDCON* makes connecting simple and secure.

CAN connection cable

SCK-401-02-4F-4M



CAN Y-junction

SCK-401-0.3-Y

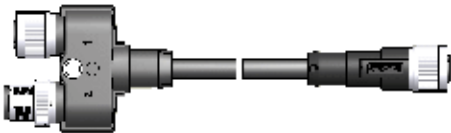

CAN terminating resistor

SCK-401-R



Cable for analog sensors

The **SensoControl**® diagnostics cable was designed for use in harsh working conditions.

5-pole version

The 5-pole cables with push-pull plugs fit to all 5-pole connections.

4-pole version

Diagnostic cables with 4-pole plugs are only compatible with the Serviceman types SCM-150-1-01/02 and SCM-152-2-08.

Connection cable (5-pin)

SCK-102-xx-02



Extension cable (5-pin)

SCK-102-05-12



Adapter

SCK-002-08

(for connecting a 4-pin sensor to a newer device)



Connection cable (4-pin)

SCK-102-02-08



* SPEEDCON® is a registered trademark of der Firma PHOENIX CONTACT GmbH & Co. KG

Housing	
Material	Cu alloy
Surface	chrom plated
Protection class (while plugged-in)	IP50

Cable	
Sheathing	PUR
Colour	black
Permissible temperatures	for stationary operations for non-stationary operations
	-20 ... +70 °C -5 ... +70 °C
Shielding	Cu meshed shield

SCK Connection Cables	#
<i>Serviceman/The Parker Service Master Family</i>	
3 m (male 5 pin - male 5 pin)	SCK-102-03-02
5 m (male 5 pin - male 5 pin)	SCK-102-05-02
5 m Extension cable (male 5 pin - female 5 pin)	SCK-102-05-12
Adapter (female 4 pin - male 5 pin)	SCK-002-08
2 m (4 pin) is only for the older versions of the Serviceman (SCM-150-1-01/02 and SCM-152-2-08)	SCK-102-02-08

SCK Connection Cables CAN*	#
<i>The Parker Service Master Plus</i>	
2 m (male 5 pin - female 5 pin)	SCK-401-02-4F-4M
5 m (male 5 pin - female 5 pin)	SCK-401-05-4F-4M
10 m (male 5 pin - female 5 pin)	SCK-401-10-4F-4M
CAN Y-splitter incl. 0,3 m cable	SCK-401-0.3-Y
CAN terminating resistor** (female 5 pin - female 5 pin)	SCK-401-R

* Other lengths available on request.

** Each CAN network requires a terminating resistor.

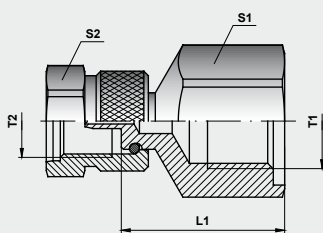

Diagnostic adapter

#	PN	P _{max}	P _{Berst}	T1	T2	L1	S1	S2
SCA-1/4-EMA-3	1.000 bar	1.200 bar	2.000 bar	1/4" BSPP	M16x2	32	27	22
SCA-1/2-EMA-3	630 bar	800 bar	1.200 bar	1/2" BSPP	M16x2	36	30	22
SCA-1/2-EMA-3-HP	1.000 bar	1.200 bar	2.000 bar	1/2" BSPP	M16x2	36	32	22

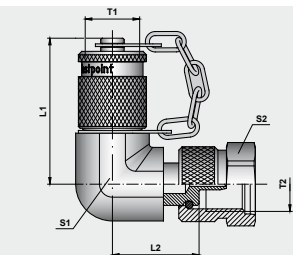

90° Diagnostic adapter with coupling

#	PN	P _{max}	P _{Berst}	T1	T2	L1	L2	S1	S2
SCA-90-EMA-3	630 bar	800 bar	1.200 bar	M16x2	M16x2	49	26	19	22

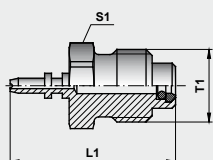

SCA-EMA-3/1

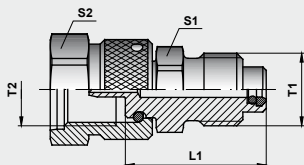

SCA-EMA-3/2

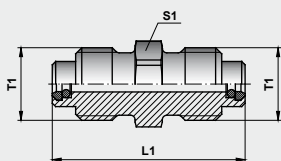

SCA-EMA-3/3

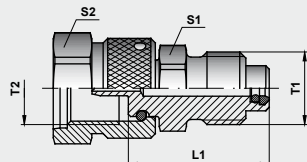

SCA-EMA-3/4

Diagnostic couplings

#	PN	P _{max}	P _{Berst}	T1	T2	L1	S1	S2
SCA-EMA-3/1	630 bar	800 bar	1.200 bar	M16x2	--	37	17	--
SCA-EMA-3/2	630 bar	800 bar	1.200 bar	M16x2	M12x1.65	31	17	17
SCA-EMA-3/3	630 bar	800 bar	1.200 bar	M16x2	M16x2	43	17	--
SCA-EMA-3/4	630 bar	800 bar	1.200 bar	M16x2	M16x1.5	31	17	17



Please pay attention to pressure range!

Parker Diagnostic quick couplings

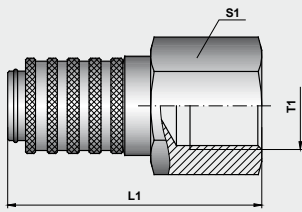

SCA-1/2-PQC

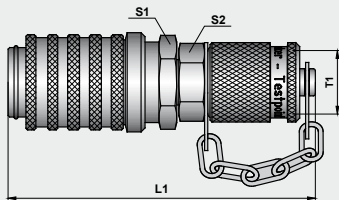

SCA-EMA-3/PQC

#	PN	P _{max}	P _{Berst}	T1	T2	L1	S1	S2
SCA-1/4-PQC	400 bar	600 bar	1.000 bar	1/4" BSPP	--	--	--	--
SCA-1/2-PQC	400 bar	600 bar	1.000 bar	1/2" BSPP	--	59	27	--
SCA-EMA-3/PQC	400 bar	600 bar	1.000 bar	M16x2	--	78	21	17



Please pay attention to pressure range!

- Sturdy and tough equipment case
- Easy operation
- Automatic sensor recognition
- PC connection
- Not dependent on main power supply



The Parker Service Master *Easy-Kit*



Serviceman-Kit



ServiceJunior-Kit

Parker hand-held measuring instruments meet the requirements of modern industrial hydraulic systems as well as those of complex mobile hydraulics. They are indispensable for maintenance of hydraulic systems.

All hydraulic parameters, such as differential pressure, flow and hydraulic power can be measured, displayed and processed.

This allows precise diagnostics in mobile hydraulics as well as in construction and agricultural machinery. Quick and convenient troubleshooting is also possible.

Furthermore, comparisons between set and actual values can be made and documented.

Parker hand-held measuring instruments are an ideal tool for all service technicians who need simple hydraulic test equipment for mobile as well as industrial hydraulics.

With the **SensoWin**® software, the data can be processed on a PC.

18 Kits and Equipment Cases for Parker Portable Measuring Instruments

SCC Equipment Case	
to carry following components	
2x Service Junior or 1x Service Junior wireless with PC-Adapter or Serviceman 2x SCK/2x SCPT/2x SMA3	SCC-340
Serviceman/The Parker Service Master <i>Easy</i> 6x SCK/8x SCPT/1x SCT/1x SCRPM 1x SCFT015/060/150/300/600 or 1x SCFT-150-DRV	SCC-DRV-300
The Parker Service Master Plus and 1x The Parker Service Master Easy or 1x Serviceman 12x SCK/ 8x SCPT/ 1x SCT/ 1x SCRPM 1x SCFT-015/060/150/300/600/750 or 1x SCFT-150-DRV	SCC-500

ServiceJunior-Kits	
Range: -1...016 bar/0...100 bar/0...400 bar/0...600 bar	SCJN-KIT-xxx*
1 Equipment Case	SCC-340
1 ServiceJunior with adapters:	SCJN-xxx-01
1 1/4 BSPP female - M16x2 female	SCA-1/4-EMA-3
1 M16x2 male - M16x2 male	SCA-EMA-3/3*
1 Test Hose 1.500 mm (M16x2)	SMA3-1500*

ServiceJunior wireless-Kits	
Range: -1...016 bar/0...100 bar/0...400 bar/0...600 bar	SCJNP-KIT-xxx-RC*
1 Equipment Case	SCC-340
1 ServiceJunior wireless	SCJNP-xxx-01-RC
1 PC-Adapter incl. Software	SCJNA-PC
with adapters:	
1 1/4 BSPP female - M16x2 female	SCA-1/4-EMA-3
1 M16x2 male - M16x2 male	SCA-EMA-3/3*
1 Test Hose 1.500 mm (M16x2)	SMA3-1500*

* not available for 1.000 bar

18 Kits and Equipment Cases for Parker Portable Measuring Instruments

Serviceman-Kits	#	#	#	#
	SCKIT-152-0-600	SCKIT-152-0-00	SCKIT-152-1-00	SCKIT-152-2-00
Equipment Case SCC-340	1	1	1	1
Serviceman	SCM-152-0-02	SCM-152-0-02	SCM-152-1-02	SCM-152-2-02
Pressure/Temperature Sensor 0 ... 600 bar SCPT-600-02-02	1	Please order accessories (SCPT/SCT/SCFT/SCRPM) separate!		
Connection Cable 3 m SCK-102-03-02	1	2	2	2
Adapter (M16x2 male - M16x2 male) SCA-EMA-3/3	1	2	2	2
Test Hose 1.500 mm (M16x2) SMA3-1500	1	2	2	2
PC-Cable (RS-232) SCK-315-02-31	--	--	--	1

The Parker Service Master <i>Easy</i>-Kits	#	#
	SCKIT-330-00	SCKIT-340-00
Equipment Case SCC-DRV-300	1	1
The Parker Service Master <i>Easy</i>	SCM-330-2-02	SCM-340-2-02
Connection Cable 3 m SCK-102-03-02	3	2
Connection Cable 5 m SCK-102-05-02	--	2
Adapter (M16x2 male - M16x2 male) SCA-EMA-3/3	2	2
Test Hose 1.500 mm (M16x2) SMA3-1500	2	2
	Please order accessories (SCPT/SCT/SCFT/SCRPM) separate!	

Serviceman-p-Q-Kit	#	#
	SCKIT-152-PQ	SCKIT-340-PTQ
The Parker Service Master <i>Easy</i>-p-Q-Kit		
Equipment Case SCC-DRV-300	1	1
Serviceman	SCM-152-2-02	--
The Parker Service Master <i>Easy</i>	--	SCM-340-2-02
Pressure/Temperature Sensor 0... 600 bar SCPT-600-02-02	1	2
Temperature Sensor SCT-150-04-02	--	1
Flow Turbine SCFT-150-DRV	1	1
Connection Cable 3 m SCK-102-03-02	2	2
Connection Cable 5 m SCK-102-05-02	--	2
Adapter (M16x2 male - M16x2 male) SCA-EMA-3/3	1	2
Test Hose 1.500 mm (M16x2) SMA3-1500	1	2

18 Kits and Equipment Cases for Parker Portable Measuring Instruments

The Parker Service Master <i>Plus</i> -Kits	#	#	#
	SCKIT-500-00-00	SCKIT-500-01-00	SCKIT-500-01-01
Equipment Case SCC-500	1	1	1
The Parker Service Master <i>Plus</i>	SCM-500-00-00	SCM-500-01-00	SCM-500-01-01
Neck Strap SC-ACC-01	1	1	1
CAN Connection Cable SCK-401-05-4F-4M	2	2	2
Terminating Resistor CAN SCK-401-R	2	2	2
Connection Cable 3 m SCK-102-03-02	–	2	3
Connection Cable 5 m SCK-102-05-02	–	1	3
Adapter (M16x2 male - M16x2 male) SCA-EMA-3/3	2	2	2
Auxiliary Sensor Adapter SCK-401-4M	–	1	2
Test Hose 1.500 mm (M16x2) SMA3-1500	2	2	2

Diagnostic Products with Calibration Certificate ISO 9001

When requested, new instruments can be delivered with a calibration certification in compliance with ISO 9001.

Instrument/Type/Kit	#
ServiceJunior	K-SCJN-xxx-01
ServiceJunior wireless	K-SCJNP-xxx-01-RC
ServiceJunior-Kits	K-SCJN-KIT-xxx
ServiceJunior wireless-Kits	K-SCJNP-KIT-xxx-RC
Serviceman	K-SCM-152-0-02 K-SCM-152-1-02 K-SCM-152-2-02
Serviceman-Kits	K-SCKIT-152-0-600 K-SCKIT-152-0-00 K-SCKIT-152-1-00 K-SCKIT-152-2-00
The Parker Service Master Easy	K-SCM-330-2-02 K-SCM-340-2-02
The Parker Service Master Easy-Kits	K-SCKIT-330-00 K-SCKIT-340-00
The Parker Service Master Plus	K-SCM-500-00-00 K-SCM-500-01-00 K-SCM-500-01-01
The Parker Service Master Plus-Kits	K-SCKIT-500-00-00 K-SCKIT-500-01-00 K-SCKIT-500-01-01
Serviceman-p-Q Kit	K-SCKIT-152-PQ
The Parker Service Master Easy-p-Q Kit	K-SCKIT-340-PTQ
SCPT Pressure/Temperature Sensor	K-SCPT-xxx-02-02
SCPT Pressure/Temperature Sensor PQC	K-SCPT-xxx-02-02-PQC
SCPT-CAN Pressure/Temperature Sensor	K-SCPT-xxx-C2-05
SCPT-CAN Pressure/Temperature Sensor PQC	K-SCPT-xxx-C2-05-PQC
SCRPM Tachometer	K-SCRPM-220
SCFT Flow Turbine	K-SCFT-xxx-02-02
SCFT-CAN Flow Turbine	K-SCFT-xxx-C2-05
SCQ Flow Transducer	K-SCQ-xxx-0-02
SCT Temperature Sensor	K-SCT-150-0-02 K-SCT-150-04-02

Example

Certificate Nr. 3143

Description:: Pressure Sensor
 Model: SCPT-600-02-02
 S/N: B1253S

Operating Range: ...600 bar
 Accuracy: ± 0,5% FS

Reference 1: Budenberg S/N 15404
 Reference 2: HP 3497A Data Logger

Cal. No. NO94 DKD-KO5801
 Cal. No. 8370831402

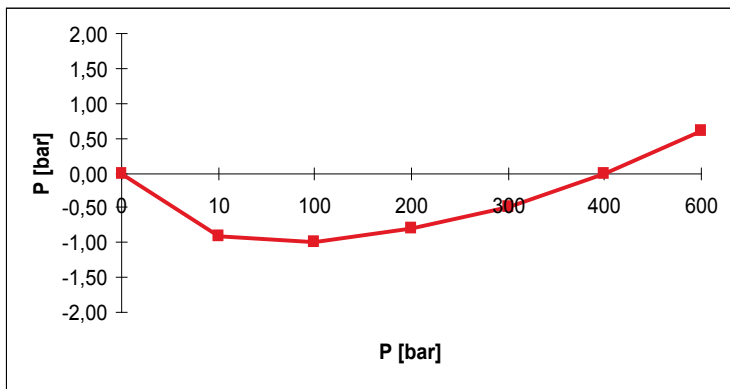

Nominal (bar)	Actual (bar)	Deviation (bar)
0	0	0,00
10	9,1	-0,90
100	99	-1,00
200	199,2	-0,80
300	299,5	-0,50
400	400	0,00
600	600,6	0,60

Parker's Motion & Control Technologies

At Parker, we're guided by a relentless drive to help our customers become more productive and achieve higher levels of profitability by engineering the best systems for their requirements. It means looking at customer applications from many angles to find new ways to create value. Whatever the motion or control technology need, Parker has the experience, breadth of product and global reach to consistently deliver. No company knows more about motion and control technology than Parker. For further information call 00800 27 27 5374



AEROSPACE

Key Markets

- Aircraft engines
- Business & general aviation
- Commercial transports
- Land-based weapons systems
- Military aircraft
- Missiles & launch vehicles
- Regional transports
- Unmanned aerial vehicles

Key Products

- Flight control systems & components
- Fluid conveyance systems
- Fluid metering delivery & atomization devices
- Fuel systems & components
- Hydraulic systems & components
- Inert nitrogen generating systems
- Pneumatic systems & components
- Wheels & brakes



CLIMATE CONTROL

Key Markets

- Agriculture
- Air conditioning
- Food, beverage & dairy
- Life sciences & medical
- Precision cooling
- Processing
- Transportation

Key Products

- CO₂ controls
- Electronic controllers
- Filter driers
- Hand shut-off valves
- Hose & fittings
- Pressure regulating valves
- Refrigerant distributors
- Safety relief valves
- Solenoid valves
- Thermostatic expansion valves



ELECTROMECHANICAL

Key Markets

- Aerospace
- Factory automation
- Life science & medical
- Machine tools
- Packaging machinery
- Paper machinery
- Plastics machinery & converting
- Primary metals
- Semiconductor & electronics
- Textile
- Wire & cable

Key Products

- AC/DC drives & systems
- Electric actuators, gantry robots & slides
- Electrohydraulic actuation systems
- Electromechanical actuation systems
- Human machine interface
- Linear motors
- Stepper motors, servo motors, drives & controls
- Structural extrusions



FILTRATION

Key Markets

- Food & beverage
- Industrial machinery
- Life sciences
- Marine
- Mobile equipment
- Oil & gas
- Power generation
- Process
- Transportation

Key Products

- Analytical gas generators
- Compressed air & gas filters
- Condition monitoring
- Engine air, fuel & oil filtration & systems
- Hydraulic, lubrication & coolant filters
- Process, chemical, water & microfiltration filters
- Nitrogen, hydrogen & zero air generators



FLUID & GAS HANDLING

Key Markets

- Aerospace
- Agriculture
- Bulk chemical handling
- Construction machinery
- Food & beverage
- Fuel & gas delivery
- Industrial machinery
- Mobile
- Oil & gas
- Transportation
- Welding

Key Products

- Brass fittings & valves
- Diagnostic equipment
- Fluid conveyance systems
- Industrial hose
- PTFE & PFA hose, tubing & plastic fittings
- Rubber & thermoplastic hose & couplings
- Tube fittings & adapters
- Quick disconnects



HYDRAULICS

Key Markets

- Aerospace
- Aerial lift
- Agriculture
- Construction machinery
- Forestry
- Industrial machinery
- Mining
- Oil & gas
- Power generation & energy
- Truck hydraulics

Key Products

- Diagnostic equipment
- Hydraulic cylinders & accumulators
- Hydraulic motors & pumps
- Hydraulic systems
- Hydraulic valves & controls
- Power take-offs
- Rubber & thermoplastic hose & couplings
- Tube fittings & adapters
- Quick disconnects



PNEUMATICS

Key Markets

- Aerospace
- Conveyor & material handling
- Factory automation
- Life science & medical
- Machine tools
- Packaging machinery
- Transportation & automotive

Key Products

- Air preparation
- Brass fittings & valves
- Manifolds
- Pneumatic accessories
- Pneumatic actuators & grippers
- Pneumatic valves & controls
- Quick disconnects
- Rotary actuators
- Rubber & thermoplastic hose & couplings
- Structural extrusions
- Thermoplastic tubing & fittings
- Vacuum generators, cups & sensors



PROCESS CONTROL

Key Markets

- Chemical & refining
- Food, beverage & dairy
- Medical & dental
- Microelectronics
- Oil & gas
- Power generation

Key Products

- Analytical sample conditioning products & systems
- Fluoropolymer chemical delivery fittings, valves & pumps
- High purity gas delivery fittings, valves & regulators
- Instrumentation fittings, valves & regulators
- Medium pressure fittings & valves
- Process control manifolds



SEALING & SHIELDING

Key Markets

- Aerospace
- Chemical processing
- Consumer
- Energy, oil & gas
- Fluid power
- General industrial
- Information technology
- Life sciences
- Military
- Semiconductor
- Telecommunications
- Transportation

Key Products

- Dynamic seals
- Elastomeric o-rings
- EMI shielding
- Extruded & precision-cut, fabricated elastomeric seals
- Homogeneous & inserted elastomeric shapes
- High temperature metal seals
- Metal & plastic retained composite seals
- Thermal management



ENGINEERING YOUR SUCCESS.

Parker Worldwide

AE – UAE, Dubai
Tel: +971 4 8127100
parker.me@parker.com

AR – Argentina, Buenos Aires
Tel: +54 3327 44 4129

AT – Austria, Wiener Neustadt
Tel: +43 (0)2622 23501-0
parker.austria@parker.com

AT – Eastern Europe, Wiener Neustadt
Tel: +43 (0)2622 23501 900
parker.easteurope@parker.com

AU – Australia, Castle Hill
Tel: +61 (0)2-9634 7777

AZ – Azerbaijan, Baku
Tel: +994 50 2233 458
parker.azerbaijan@parker.com

BE/LU – Belgium, Nivelles
Tel: +32 (0)67 280 900
parker.belgium@parker.com

BR – Brazil, Cachoeirinha RS
Tel: +55 51 3470 9144

BY – Belarus, Minsk
Tel: +375 17 209 9399
parker.belarus@parker.com

CA – Canada, Milton, Ontario
Tel: +1 905 693 3000

CH – Switzerland, Etoy
Tel: +41 (0) 21 821 87 00
parker.switzerland@parker.com

CL – Chile, Santiago
Tel: +56 2 623 1216

CN – China, Shanghai
Tel: +86 21 2899 5000

CZ – Czech Republic, Klecany
Tel: +420 284 083 111
parker.czechrepublic@parker.com

DE – Germany, Kaarst
Tel: +49 (0)2131 4016 0
parker.germany@parker.com

DK – Denmark, Ballerup
Tel: +45 43 56 04 00
parker.denmark@parker.com

ES – Spain, Madrid
Tel: +34 902 330 001
parker.spain@parker.com

FI – Finland, Vantaa
Tel: +358 (0)20 753 2500
parker.finland@parker.com

FR – France, Contamine s/Arve
Tel: +33 (0)4 50 25 80 25
parker.france@parker.com

GR – Greece, Athens
Tel: +30 210 933 6450
parker.greece@parker.com

HK – Hong Kong
Tel: +852 2428 8008

HU – Hungary, Budapest
Tel: +36 1 220 4155
parker.hungary@parker.com

IE – Ireland, Dublin
Tel: +353 (0)1 466 6370
parker.ireland@parker.com

IN – India, Mumbai
Tel: +91 22 6513 7081-85

IT – Italy, Corsico (MI)
Tel: +39 02 45 19 21
parker.italy@parker.com

JP – Japan, Tokyo
Tel: +(81) 3 6408 3901

KR – South Korea, Seoul
Tel: +82 2 559 0400

KZ – Kazakhstan, Almaty
Tel: +7 7272 505 800
parker.easteurope@parker.com

LV – Latvia, Riga
Tel: +371 6 745 2601
parker.latvia@parker.com

MX – Mexico, Apodaca
Tel: +52 81 8156 6000

MY – Malaysia, Shah Alam
Tel: +60 3 7849 0800

NL – The Netherlands, Oldenzaal
Tel: +31 (0)541 585 000
parker.nl@parker.com

NO – Norway, Ski
Tel: +47 64 91 10 00
parker.norway@parker.com

NZ – New Zealand, Mt Wellington
Tel: +64 9 574 1744

PL – Poland, Warsaw
Tel: +48 (0)22 573 24 00
parker.poland@parker.com

PT – Portugal, Leca da Palmeira
Tel: +351 22 999 7360
parker.portugal@parker.com

RO – Romania, Bucharest
Tel: +40 21 252 1382
parker.romania@parker.com

RU – Russia, Moscow
Tel: +7 495 645-2156
parker.russia@parker.com

SE – Sweden, Spånga
Tel: +46 (0)8 59 79 50 00
parker.sweden@parker.com

SG – Singapore
Tel: +65 6887 6300

SK – Slovakia, Banská Bystrica
Tel: +421 484 162 252
parker.slovakia@parker.com

SL – Slovenia, Novo Mesto
Tel: +386 7 337 6650
parker.slovenia@parker.com

TH – Thailand, Bangkok
Tel: +662 717 8140

TR – Turkey, Istanbul
Tel: +90 216 4997081
parker.turkey@parker.com

TW – Taiwan, Taipei
Tel: +886 2 2298 8987

UA – Ukraine, Kiev
Tel: +380 44 494 2731
parker.ukraine@parker.com

UK – United Kingdom, Warwick
Tel: +44 (0)1926 317 878
parker.uk@parker.com

US – USA, Cleveland
Tel: +1 216 896 3000

VE – Venezuela, Caracas
Tel: +58 212 238 5422

ZA – South Africa, Kempton Park
Tel: +27 (0)11 961 0700
parker.southafrica@parker.com

European Product Information Centre
Free phone: 00 800 27 27 5374
(from AT, BE, CH, CZ, DE, DK, EE, ES, FI,
FR, IE, IL, IS, IT, LU, MT, NL, NO, PL, PT, RU,
SE, UK, ZA)

