



Vaporizing Regulators

Instrument / Analyzer Products

*Catalog 4512/USA
April 2005*

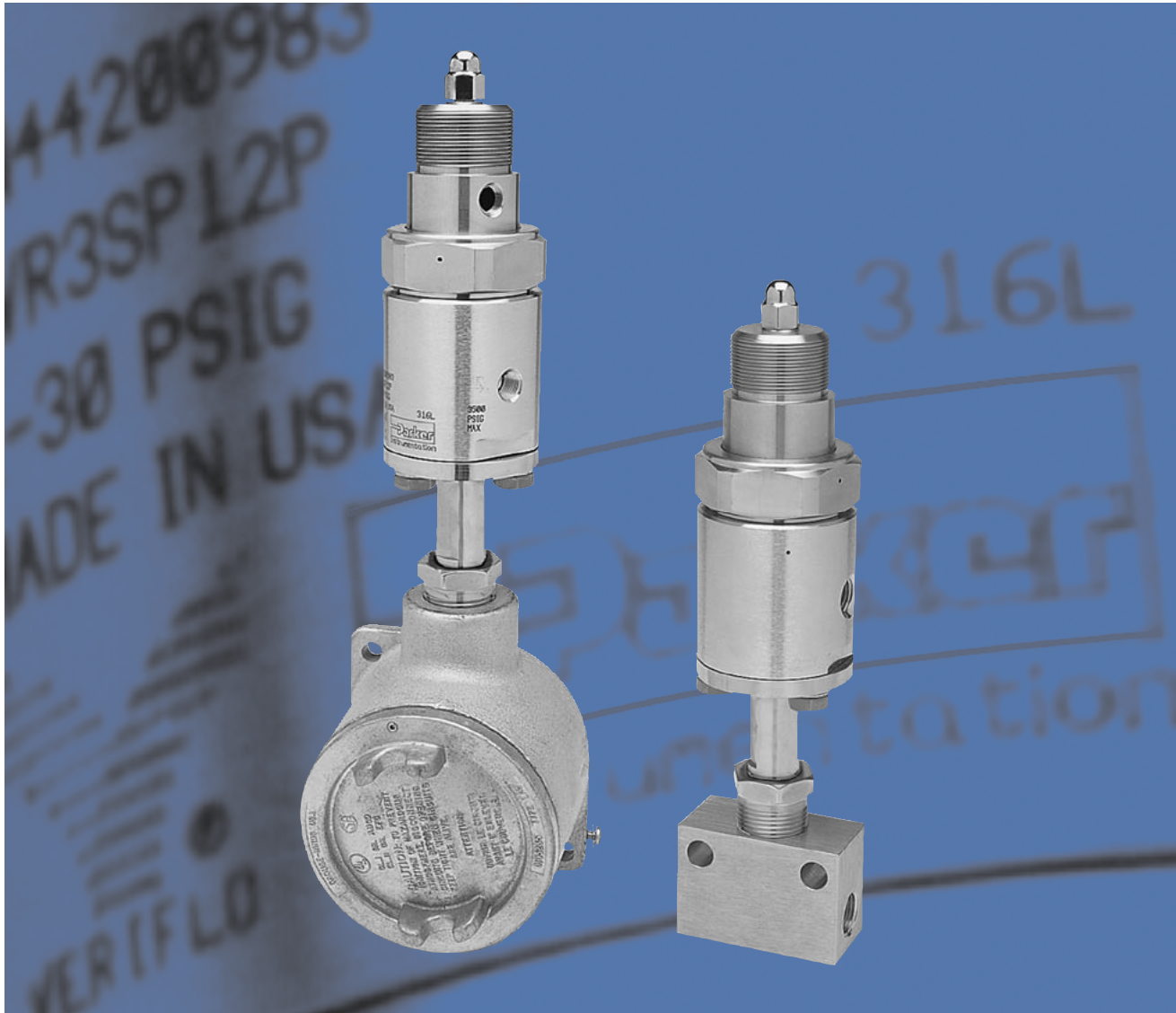

Table of Contents

Veriflo Division	3
AVR3 Series – Steam Heated Pressure Reducing Regulator	5
Features	5
Specifications	5
Flow Curves	6
Seat Operating Parameters	6
Ordering Information	7
Cross Sectional View and Installation Dimensions	8
Porting Configurations	8
AVR4 Series – Electrically Heated Pressure Reducing Regulator	9
Features	9
Specifications	9
Flow Curves	10
Seat Operating Parameters	10
Ordering Information	11
Product Certifications	11
Cross Sectional View and Installation Dimensions	12
Porting Configurations	12
Offer of Sale	14
Parker Overview	15



Veriflo

A Leading Manufacturer of Precision Valves, Regulators & Surface Mount Components

Veriflo Division, Parker Hannifin Corporation is a leading manufacturer of precision valves, regulators and surface mount components for the control and application of liquids and gases used in the fabrication of semiconductors, as well as in the chemical and petrochemical industries.

Veriflo has maintained industry leadership over the past 95 years through innovative engineering, manufacturing and by placing a premium on quality customer care.

The division maintains two state-of-the-art Class 10 Clean Rooms at its Richmond, CA, facility and has adopted a corporate wide “Lean Manufacturing” philosophy, which is delivering greater value to the customer by eliminating wasteful steps through continuous improvement activities.

Veriflo Division’s two manufacturing facilities develop and manufacture applications for the Semiconductor/High Purity and Instrument/Analyzer industries.



! WARNING

FAILURE OR IMPROPER SELECTION OR IMPROPER USE OF THE PRODUCTS AND/OR SYSTEMS DESCRIBED HEREIN OR RELATED ITEMS CAN CAUSE DEATH, PERSONAL INJURY AND PROPERTY DAMAGE.

This document and other information from Parker Hannifin Corporation, its subsidiaries and authorized distributors provide product and/or system options for further investigation by users having technical expertise. It is important that you analyze all aspects of your application and review the information concerning the product or system in the current product catalog. Due to the variety of operating conditions and applications for these products or systems, the user, through its own analysis and testing, is solely responsible for making the final selection of the products and systems and assuring that all performance, safety and warning requirements of the application are met.

The products described herein, including without limitation, product features, specifications, designs, availability and pricing, are subject to change by Parker Hannifin Corporation and its subsidiaries at any time without notice.

Offer of Sale

The items described in this document are hereby offered for sale by Parker Hannifin Corporation, its subsidiaries or its authorized distributors. This offer and its acceptance are governed by the provisions stated in the “Offer of Sale” located in Catalog 4230/4233 CPI™/A-Lok® Tube Fittings.



Placing a Premium on Quality Customer Care

With the focus of maintaining the highest industry standards, Veriflo Division has achieved an ISO 9001 registration at both its Richmond, CA, manufacturing plant and at its Carson City, NV, facility. This certification confirms Veriflo's commitment to quality and excellence as recognized by the international community.

The Instrumentation Group of Parker Hannifin specializes in high quality, critical flow components for world-wide process instrumentation, ultra-high purity, medical, analytical and biopharmaceutical applications.

Parker's Instrumentation Group has ten manufacturing plants and over 300 authorized distributor locations around the world to provide local inventory and technical support. Key markets for the Instrumentation Group include: Chemical Process, Power Generation, Oil and Gas Exploration, Semiconductor Manufacturing, Biomedical, and Analytical Equipment.



Visit Us on the Web

For further information on Veriflo Division and or its product line [visit the division web site at www.veriflo.com](http://www.veriflo.com). For more information on Parker Hannifin Corporation [visit the corporation's web site at www.parker.com](http://www.parker.com).



Hastelloy C-22® is a registered trademark of Haynes International, Inc.
 Inconel® is a registered trademark of Inco Alloys International.
 Monel® is a registered trademark of International Nickel Company.
 Vespel® is a registered trademark of DuPont Company
 Eligiloy® is a registered trademark of Elgiloy Corp.
 PEEK™ is a trademark of Victrex plc.

Steam Heated Pressure Reducing Regulator

Parker Hannifin Corporation's Veriflo Division presents the AVR3 Series steam heated pressure reducing vaporizing regulator. The AVR3 is designed to heat and/or vaporize a gas or liquid sample before entering an analyzer system. The design allows easy cleaning of the heating element and screen.



Features

- ▶ Ultra low internal volume.
- ▶ Standard Hastelloy C-22[®] diaphragm for superior strength and corrosion resistance.
- ▶ Convuluted diaphragm provides outlet pressure stability with changes in flow.
- ▶ Integral diaphragm stop provides additional measure of safety.
- ▶ Meets ANSI/NACE MR0175/ISO15156.
- ▶ Field serviceable heat transfer element.
- ▶ O₂ cleaned.

Specifications

Materials of Construction

Wetted

Pressure Control and Heat Exchanger

Bodies.....	316L Stainless Steel or Monel [®]
Seat	PCTFE, PEEK [™] , or Vespel [®]
Heater Seal.....	PEEK [™]
Back-up O-ring	Fluorocarbon
Carrier	Stainless Steel*
Compression Member	Inconel [®]
Diaphragm	Hastelloy C-22 [®]
Poppet	Elgiloy [®]
Poppet Spring.....	Inconel [®]

Nonwetted

Cap	303 Stainless Steel
Cap Nut	316L Stainless Steel

Operating Conditions

Maximum Inlet Pressure.....	3500 psig (241 barg)
Outlet Pressure.....	1-10 psig (.7 barg), 1-30 psig (2 barg), 2-60 psig (4 barg), 3-100 psig (7 barg), 10-250 psig (17 barg), 20-500 psig (35 barg)
Maximum Steam Supply.....	600 psig, 500°F (41 barg), (260°C)
Temperature of Flow Media	-40°F to 500°F (-40°C to 260°C) Seat Material Specific

Functional Performance

Design Proof Pressure	5250 psig (362 barg)
Design Burst Pressure.....	11,500 psig (793 barg)
Flow Capacity	C _v 0.06 Nominal (SEMI Flow Coefficient Test # F-32-0998)
Supply Pressure Effect	0.5 psig per 100 psig (.03 barg per 7 barg)

Maximum Inboard Design

Leak Rate	< 2 x 10 ⁻⁷ scc/sec He
-----------------	-----------------------------------

Internal Volume

High Pressure Inlet 0.57 cc, Overall 4.6 cc

Standard Connections

1/4" NPT outlet ports, 1/8" NPT or 1/8" low volume internal compression inlet port, 3/8" NPT steam supply connections

Approximate Weight

.....	8 lbs (2.0 kgm)
-------	-----------------

* Proprietary Carpenter Stainless Steel with corrosion resistance equal or better than 316 Stainless Steel.

Flow Curves

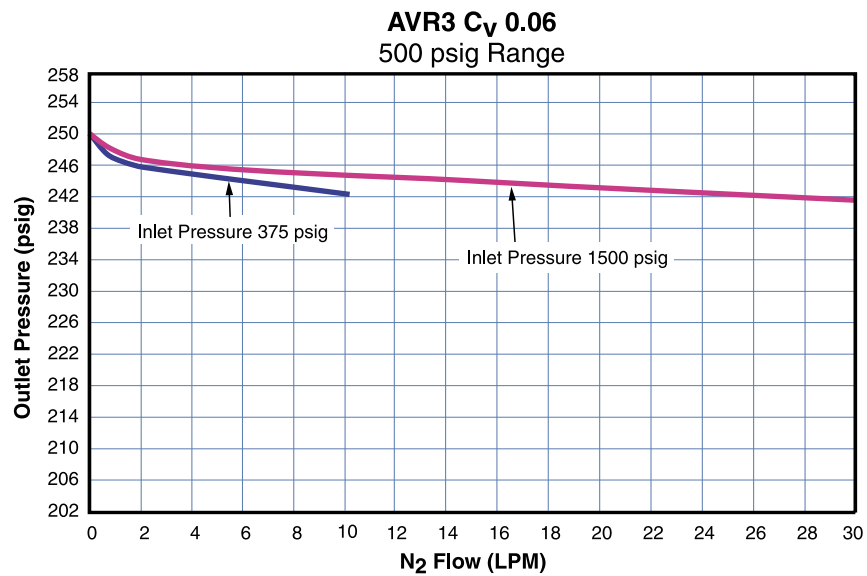
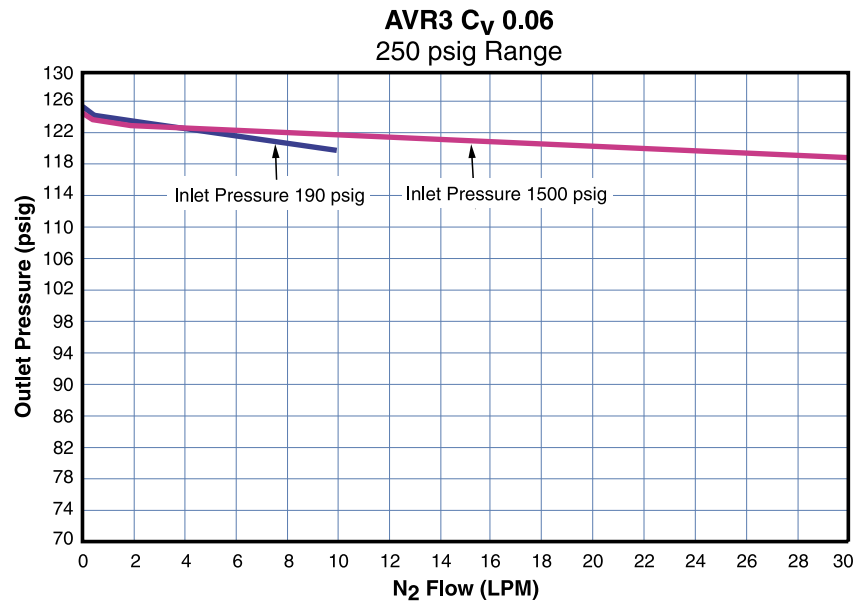

Seat Operating Parameters

Seat Material	Temperature	Inlet Pressure
PCTFE	150°F (66°C)	3500 psig (241 barg)
PEEK™	275°F (135°C)	3500 psig (241 barg)
VespeI®	500°F (260°C)	3500 psig (241 barg)

Ordering Information

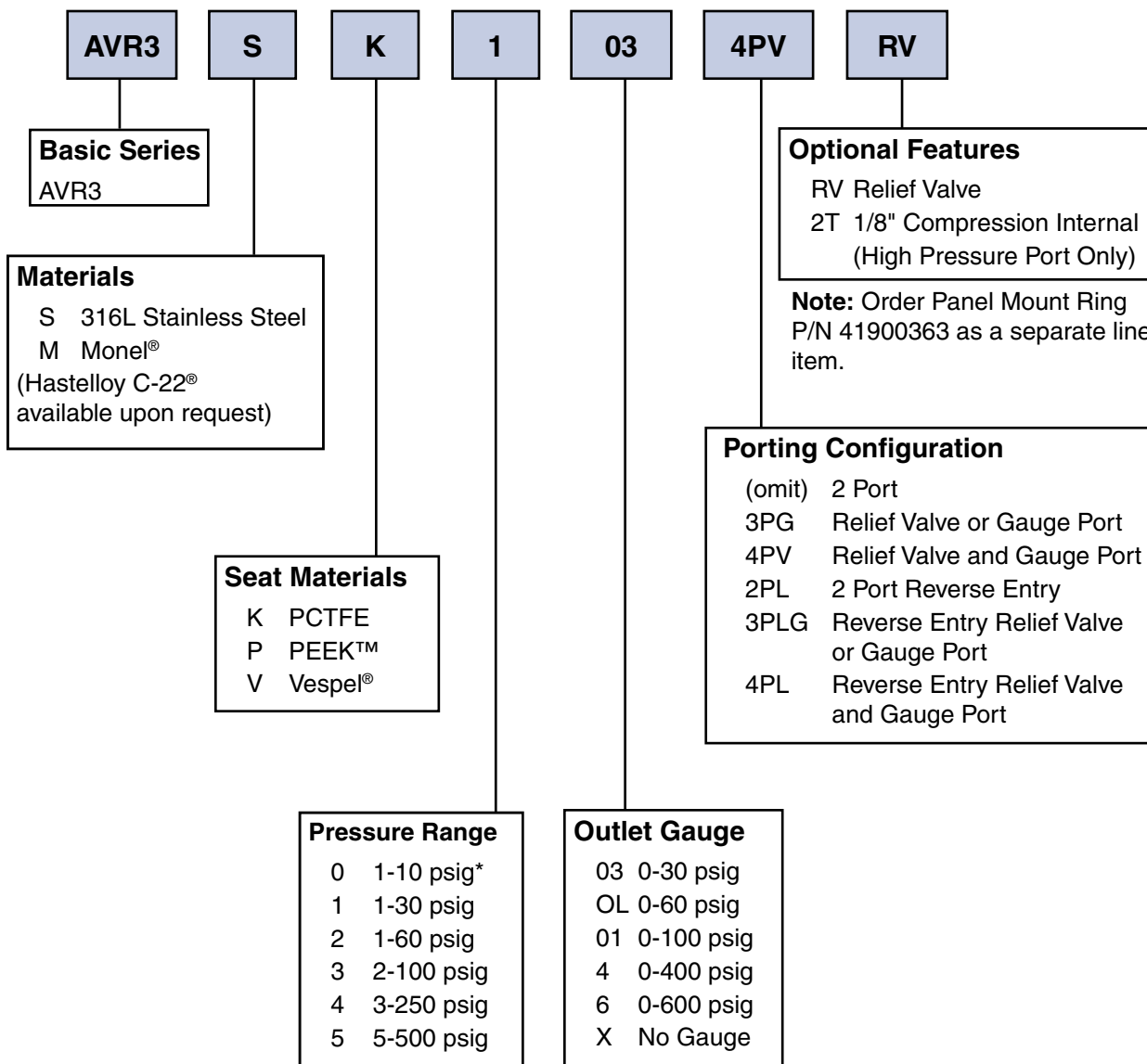

* Max inlet 250 psig

Cross Sectional View and Installation Dimensions

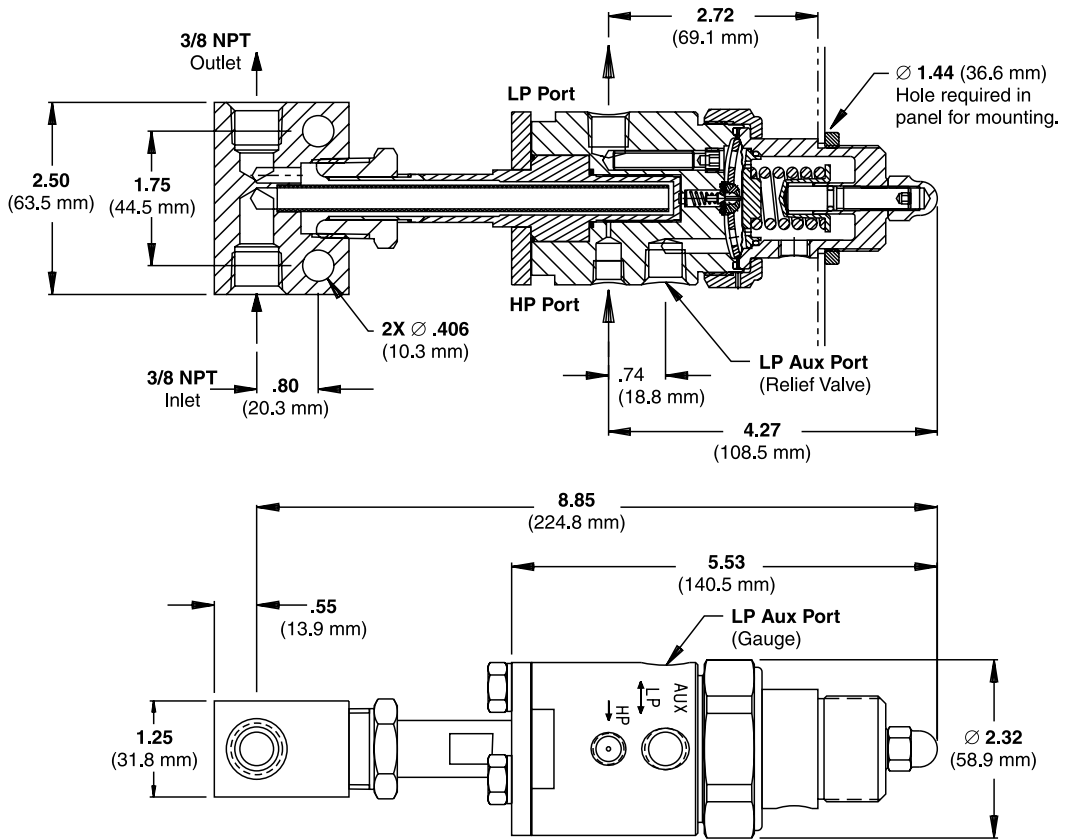

Porting Configurations

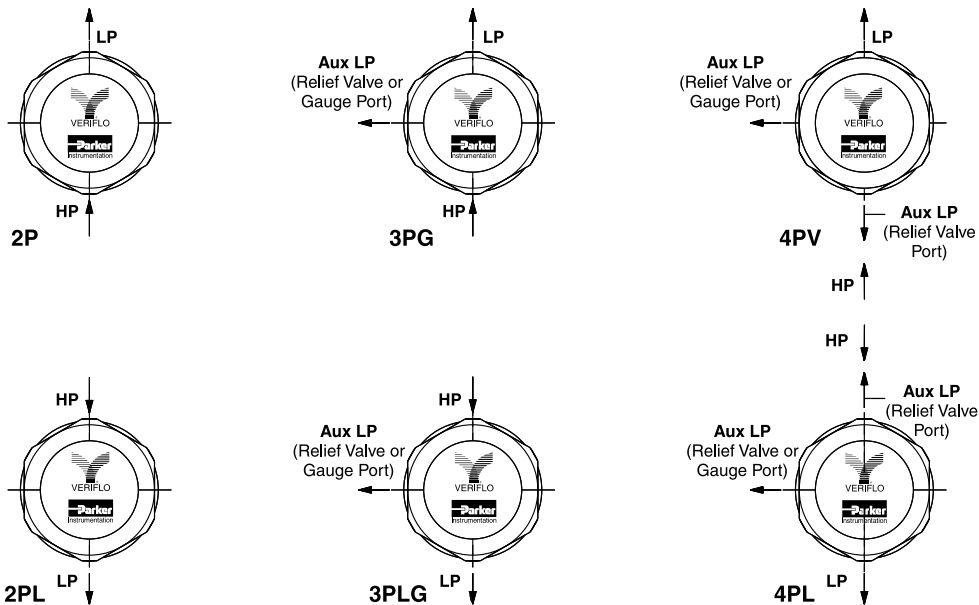

Electrically Heated Pressure Reducing Regulator

Parker Hannifin Corporation's Veriflo Division presents the AVR4 Series electronically heated vaporizing pressure reducing regulator. The AVR4 Series is for use in potentially explosive atmospheres.

The AVR4 is designed to heat and/or vaporize a gas or liquid sample before entering an analyzer system. The design allows easy cleaning of the heating element and screen, reducing expensive replacement costs.



Features

- ▶ Ultra low internal volume.
- ▶ Standard Hastelloy C-22® diaphragm for superior strength and corrosion resistance.
- ▶ Convuluted diaphragm provides outlet pressure stability with changes in flow.
- ▶ Integral diaphragm stop provides additional safety measure.
- ▶ Meets ANSI/NACE MR0175/ISO15156.
- ▶ CSA, CE-ATEX certified.
- ▶ Field serviceable heat transfer element.
- ▶ O₂ cleaned.

ATEX Related Drawing:
Revision Control Per 54099313
Reference: ATEX Schedule Drawing 54013150
Reference: CSA File # LR99181

Specifications

Materials of Construction

Wetted

Pressure control and heat exchanger
Bodies..... 316L Stainless Steel or Monel®
Seat PCTFE, PEEK™, or Vespel®
Heater Seal..... PEEK™
Back-up O-ring Fluorocarbon
Carrier Stainless Steel*
Compression Member Inconel®
Diaphragm Hastelloy C-22®
Poppet Elgiloy®
Poppet Spring..... Inconel®

Nonwetted

Cap 303 Stainless Steel
Cap Nut 316L Stainless Steel
Condulet Cast iron and aluminum

Electrical Specifications

Power Requirements 120V or 240V, 50/60 Hz
Heater Wattage..... 40, 100, 150, 200 watt
Temperature Controller Proportional,
75°F to 220°F or 215°F to 380°F
(24°C to 105°C or 102°C to 194°C)
Ranges Approximate
Condulet Crouse Hinds, UL and CSA listed Class 1,
Groups A, B, C, D; Class 2, Groups E, F, G

Operating Conditions

Maximum Inlet Pressure..... 3500 psig (241 barg)
Outlet Pressure..... 1-10 psig (.7 barg), 1-30 psig (2 barg),
2-60 psig (4 barg), 3-100 psig (7 barg),
10-250 psig (17 barg), 20-500 psig (35 barg)
Temperature of Flow Media -40°F to 500°F
(-40°C to 260°C) Seat Material Specific

Functional Performance

Design Proof Pressure 5,250 psig (362 barg)
Design Burst Pressure..... 11,500 psig (793 barg)
Flow Capacity C_v 0.06 Nominal
(SEMI Flow Coefficient Test # F-32-0998)
Supply Pressure Effect 0.5 psig per 100 psig
(.03 barg per 7 barg)
Maximum Inboard Design Leak Rate < 2 x 10⁻⁷ scc/sec He

Internal Volume

High Pressure Inlet 0.57 cc, Overall 4.6 cc

Standard Connections

1/4" NPT outlet ports, 1/8" NPT or 1/8" low volume internal compression inlet port,

Approximate Weight

..... 8 lbs (2.0 kgm)

* Proprietary Carpenter Stainless Steel with corrosion resistance equal or better than 316 Stainless Steel.

Flow Curves

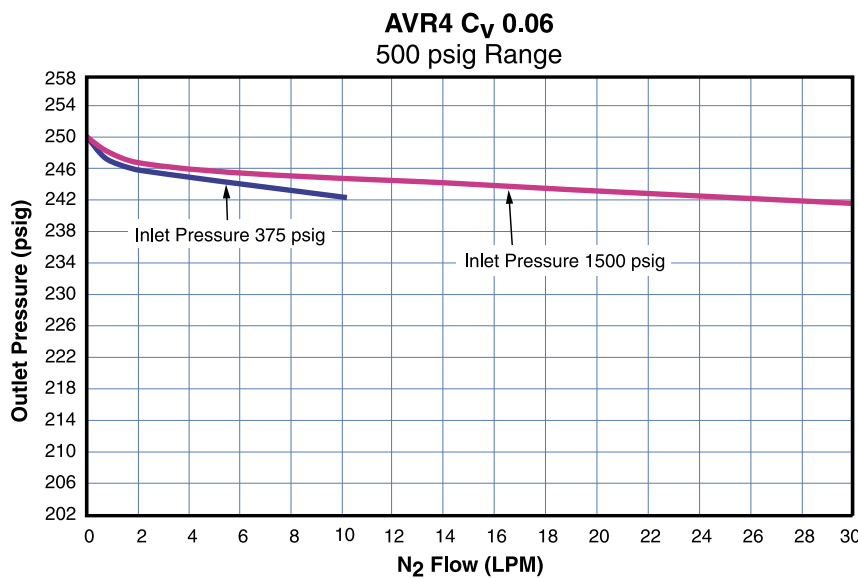
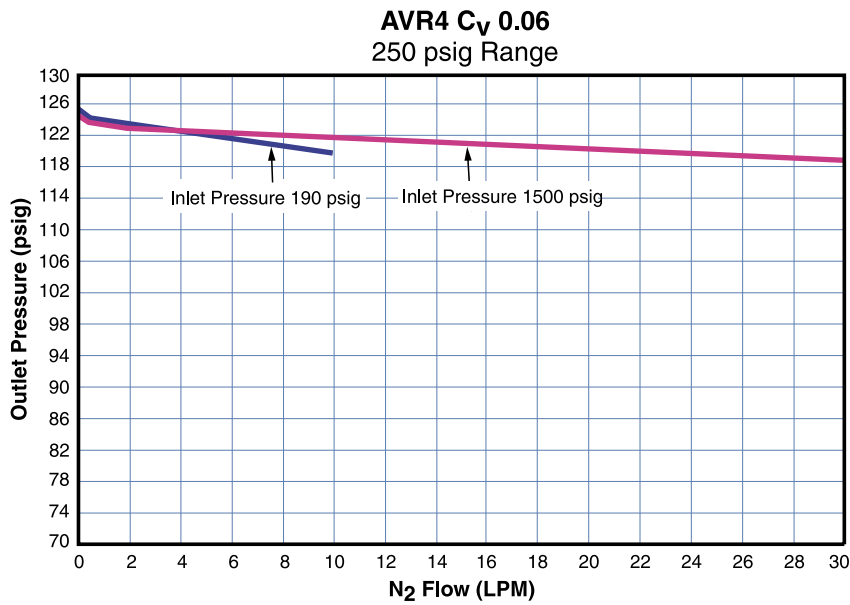

Seat Operating Parameters

Seat Material	Temperature	Inlet Pressure
PCTFE	150°F (66°C)	3500 psig (241 barg)
PEEK™	275°F (135°C)	3500 psig (241 barg)
VespeI®	500°F (260°C)	3500 psig (241 barg)

Ordering Information

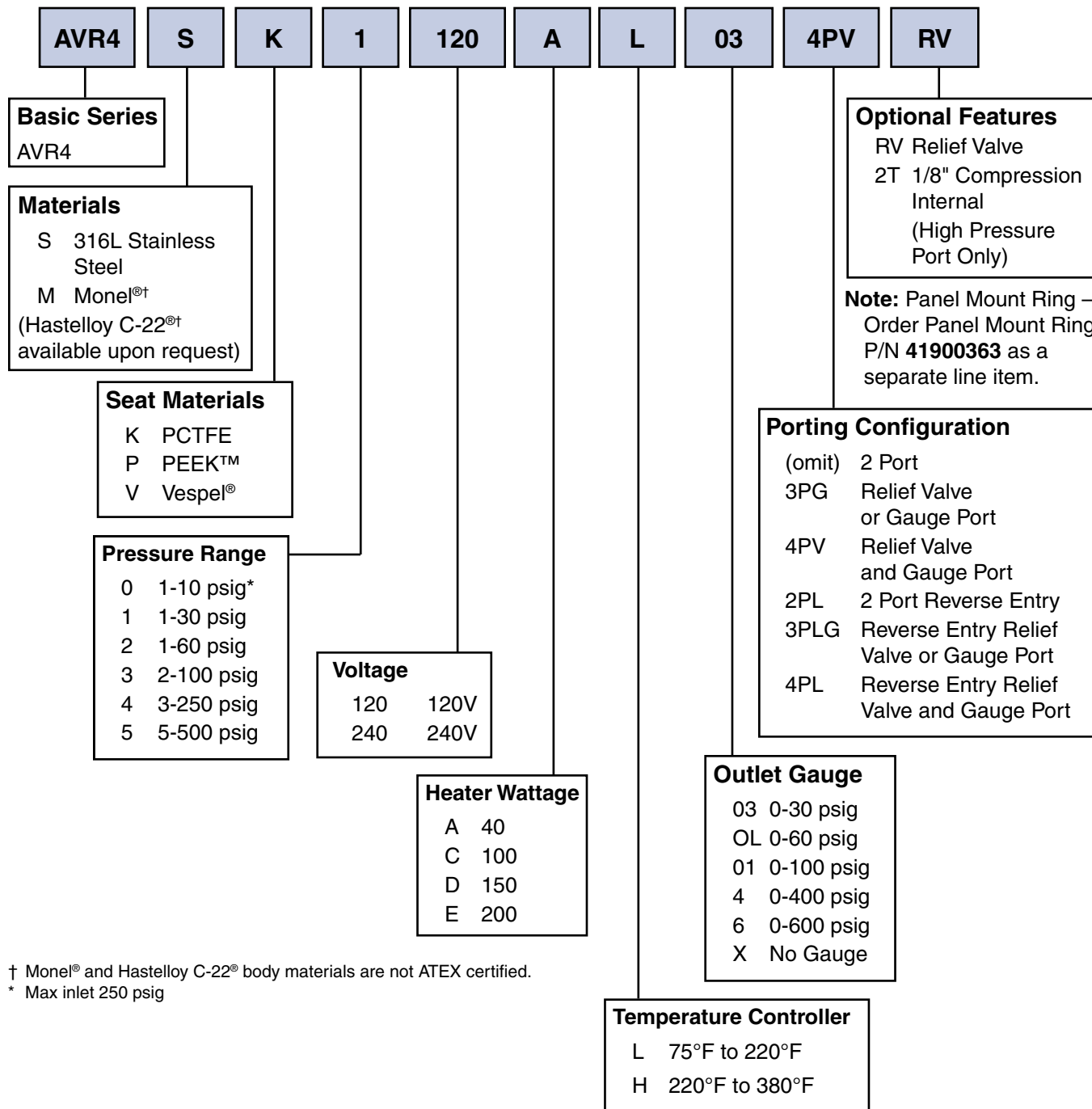

† Monel® and Hastelloy C-22® body materials are not ATEX certified.

* Max inlet 250 psig

Product Certifications	
North American Certification	CLASS I GROUPS A, B, C & D US LR99181
European Union Certification	0344 II 2 G EExdIIC T3 KEMA 03ATEX2359

Cross Sectional View and Installation Dimensions

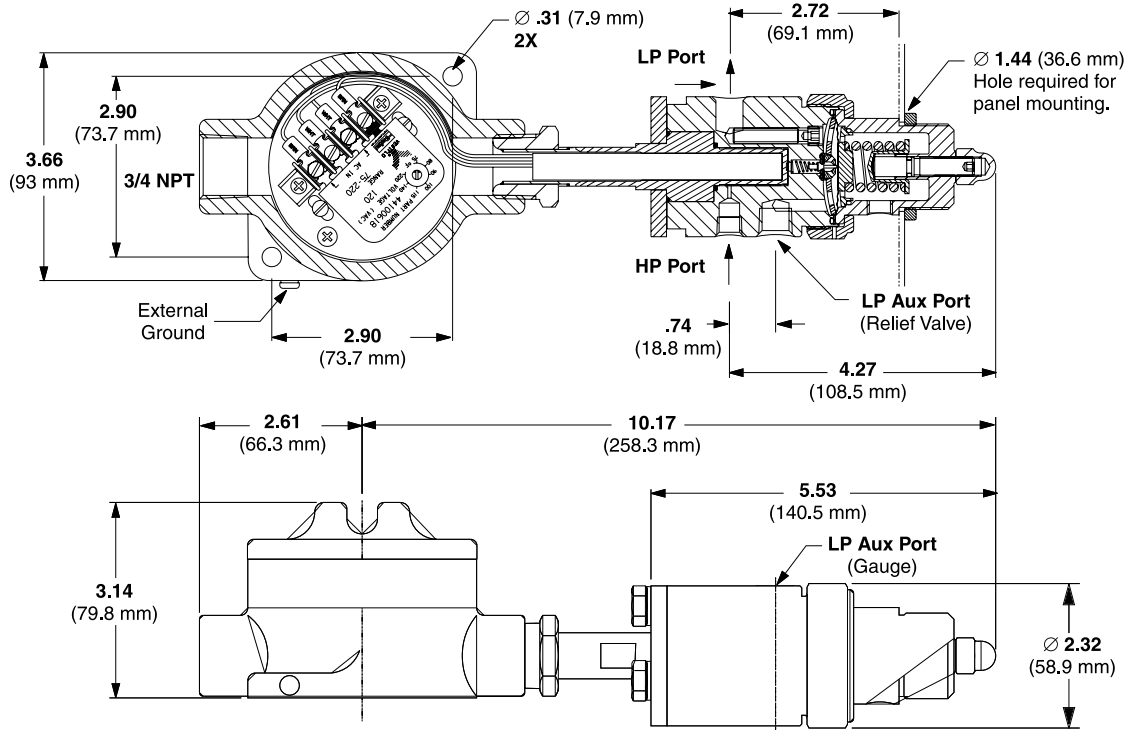

Porting Configurations

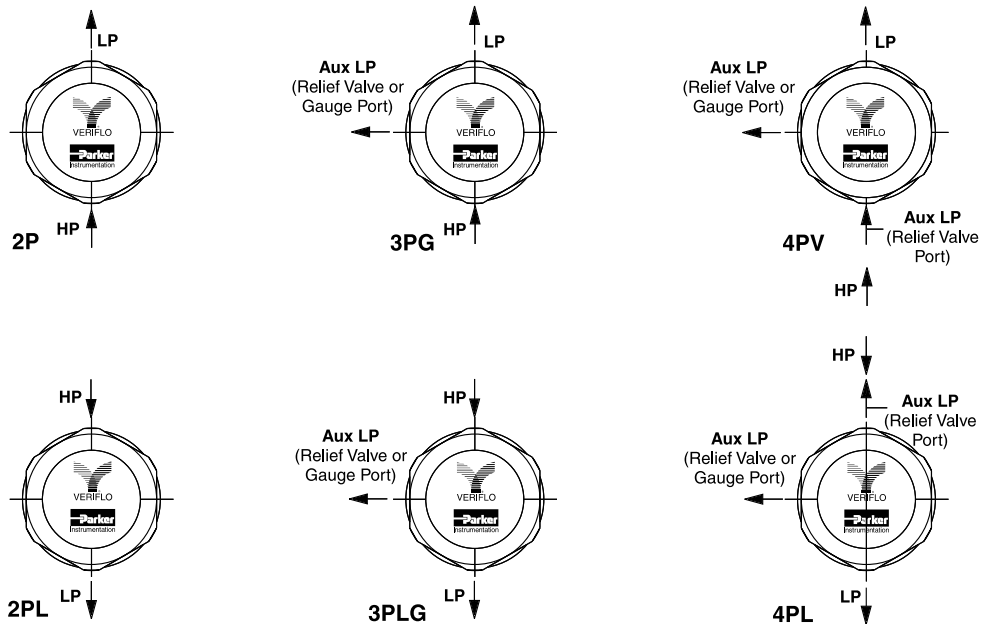

The items described in this document and other documents or descriptions provided by Parker Hannifin Corporation, its subsidiaries and its authorized distributors are hereby offered for sale at prices to be established by Parker Hannifin Corporation, its subsidiaries and its authorized distributors. This offer and its acceptance by any customer ("Buyer") shall be governed by all of the following Terms and Conditions. Buyer's order for any such items, when communicated to Parker Hannifin Corporation, its subsidiary or an authorized distributor ("Seller") verbally or in writing, shall constitute acceptance of this offer.

1. **Terms and Conditions of Sale:** All descriptions, quotations, proposals, offers, acknowledgments, acceptances and sales of Seller's products are subject to and shall be governed exclusively by the terms and conditions stated herein. Buyer's acceptance of any offer to sell is limited to these terms and conditions. Any terms or conditions in addition to, or inconsistent with those stated herein, proposed by Buyer in any acceptance of an offer by Seller, are hereby objected to. No such additional, different or inconsistent terms and conditions shall become part of the contract between Buyer and Seller unless expressly accepted in writing by Seller. Seller's acceptance of any offer to purchase by Buyer is expressly conditional upon Buyer's assent to all the terms and conditions stated herein, including any terms in addition to, or inconsistent with those contained in Buyer's offer. Acceptance of Seller's products shall in all events constitute such assent.

2. **Payment:** Payment shall be made by Buyer net 30 days from the date of delivery of the items purchased hereunder. Amounts not timely paid shall bear interest at the maximum rate permitted by law for each month or portion thereof that the Buyer is late in making payment. Any claims by Buyer for omissions or shortages in a shipment shall be waived unless Seller receives notice thereof within 30 days after Buyer's receipt of the shipment.

3. **Delivery:** Unless otherwise provided on the face hereof, delivery shall be made F.O.B. Seller's plant. Regardless of the method of delivery, however, risk of loss shall pass to Buyer upon Seller's delivery to a carrier. Any delivery dates shown are approximate only and Seller shall have no liability for any delays in delivery.

4. **Warranty:** Seller warrants that the items sold hereunder shall be free from defects in material or workmanship for a period of 18 months from date of shipment from Parker Hannifin Corporation. THIS WARRANTY COMPRISES THE SOLE AND ENTIRE WARRANTY PERTAINING TO ITEMS PROVIDED HEREUNDER. SELLER MAKES NO OTHER WARRANTY, GUARANTEE, OR REPRESENTATION OF ANY KIND WHATSOEVER. ALL OTHER WARRANTIES, INCLUDING BUT NOT LIMITED TO, MERCHANTABILITY AND FITNESS FOR PURPOSE, WHETHER EXPRESS, IMPLIED, OR ARISING BY OPERATION OF LAW, TRADE USAGE, OR COURSE OF DEALING ARE HEREBY DISCLAIMED.

NOTWITHSTANDING THE FOREGOING, THERE ARE NO WARRANTIES WHATSOEVER ON ITEMS BUILT OR ACQUIRED WHOLLY OR PARTIALLY, TO BUYER'S DESIGNS OR SPECIFICATIONS.

5. **Limitation Of Remedy:** SELLER'S LIABILITY ARISING FROM OR IN ANY WAY CONNECTED WITH THE ITEMS SOLD OR THIS CONTRACT SHALL BE LIMITED EXCLUSIVELY TO REPAIR OR REPLACEMENT OF THE ITEMS SOLD OR REFUND OF THE PURCHASE PRICE PAID BY BUYER, AT SELLER'S SOLE OPTION. IN NO EVENT SHALL SELLER BE LIABLE FOR ANY INCIDENTAL, CONSEQUENTIAL OR SPECIAL DAMAGES OF ANY KIND OR NATURE WHATSOEVER, INC.

INCLUDING BUT NOT LIMITED TO LOST PROFITS ARISING FROM OR IN ANY WAY CONNECTED WITH THIS AGREEMENT OR ITEMS SOLD HEREUNDER, WHETHER ALLEGED TO ARISE FROM BREACH OF CONTRACT, EXPRESS OR IMPLIED WARRANTY, OR IN TORT, INCLUDING WITHOUT LIMITATION, NEGLIGENCE, FAILURE TO WARN OR STRICT LIABILITY.

6. **Changes, Reschedules and Cancellations:** Buyer may request to modify the designs or specifications for the items sold hereunder as well as the quantities and delivery dates thereof, or may request to cancel all or part of this order, however, no such requested modification or cancellation shall become part of the contract between Buyer and Seller unless accepted by Seller in a written amendment to this Agreement. Acceptance of any such requested modification or cancellation shall be at Seller's discretion, and shall be upon such terms and conditions as Seller may require.

7. **Special Tooling:** A tooling charge may be imposed for any special tooling, including without limitation, dies, fixtures, molds and patterns, acquired to manufacture items sold pursuant to this contract. Such special tooling shall be and remain Seller's property notwithstanding payment of any charges by Buyer. In no event will Buyer acquire any interest in apparatus belonging to Seller which is utilized in the notwithstanding any charges paid by Buyer. Unless otherwise agreed, Seller shall have the right to alter, discard or otherwise dispose of any special tooling or other property in its sole discretion at any time.

8. **Buyer's Property:** Any designs, tools, patterns, materials, drawings, confidential information or equipment furnished by Buyer or any other items which become Buyer's property, may be considered obsolete and may be destroyed by Seller after two (2) consecutive years have elapsed without Buyer placing an order for the items which are manufactured using such property, Seller shall not be responsible for any loss or damage to such property while it is in Seller's possession or control.

9. **Taxes:** Unless otherwise indicated on the face hereof, all prices and charges are exclusive of excise, sales, use, property, occupational or like taxes which may be imposed by any taxing authority upon the manufacture, sale or delivery of the items sold hereunder. If any such taxes must be paid by Seller or if Seller is liable for the collection of such tax, the amount thereof shall be in addition to the amounts for the items sold. Buyer agrees to pay all such taxes or to reimburse Seller therefore upon receipt of its invoice. If Buyer claims exemption from any sales, use or other tax imposed by any taxing authority, Buyer shall save Seller harmless from and against any such tax, together with any interest or penalties thereon which may be assessed if the items are held to be taxable.

10. **Indemnity For Infringement of Intellectual Property Rights:** Seller shall have no liability for infringement of any patents, trademarks, copyrights, trade dress, trade secrets or similar rights except as provided in this Part

10. Seller will defend and indemnify Buyer against allegations of infringement of U.S. Patents, U.S. Trademarks, copyrights, trade dress and trade secrets (hereinafter 'Intellectual Property Rights'). Seller will defend at its expense and will pay the cost of any settlement or damages awarded in an action brought against Buyer based on an allegation that an item sold pursuant to this contract infringes the Intellectual Property Rights of a third party. Seller's obligation to defend and indemnify Buyer is contingent on Buyer notifying Seller within ten (10) days after Buyer becomes aware of such allegations of infringement, and Seller having sole control over the defense of any allegations or actions including all negotiations for settlement or compromise. If an item sold hereunder is subject to a claim that it infringes the Intellectual Property Rights of a third party, Seller may, at its sole expense and option, procure for Buyer the right to continue using said item, replace or modify said item so as to make it noninfringing, or offer to accept return of said item and return the purchase price less a reasonable allowance for depreciation. Notwithstanding the foregoing, Seller shall have no liability for claims of infringement based on information provided by Buyer, or directed to items delivered hereunder for which the designs are specified in whole or part by Buyer, or infringements resulting from the modification, combination or use in a system of any item sold hereunder. The foregoing provisions of this Part 10 shall constitute Seller's sole and exclusive liability and Buyer's sole and exclusive remedy for infringement of Intellectual Property Rights.

If a claim is based on information provided by Buyer or if the design for an item delivered hereunder is specified in whole or in part by Buyer, Buyer shall defend and indemnify Seller for all costs, expenses or judgments resulting from any claim that such item infringes any patent, trademark, copyright, trade dress, trade secret or any similar right.

11. **Force Majeure:** Seller does not assume the risk of and shall not be liable for delay or failure to perform any of Seller's obligations by reason of circumstances beyond the reasonable control of Seller (hereinafter 'Events of Force Majeure'). Events of Force Majeure shall include without limitation, accidents, acts of God, strikes or labor disputes, acts, laws, rules or regulations of any government or government agency, fires, floods, delays or failures in delivery of carriers or suppliers, shortages of materials and any other cause beyond Seller's control.

12. **Entire Agreement/Governing Law:** The terms and conditions set forth herein, together with any amendments, modifications and any different terms or conditions expressly accepted by Seller in writing, shall constitute the entire Agreement concerning the items sold, and there are no oral or other representations or agreements which pertain thereto. This Agreement shall be governed in all respects by the law of the State of Ohio. No actions arising out of the sale of the items sold hereunder or this Agreement may be brought by either party more than two (2) years after the cause of action accrues.

9/91-P



Parker Hannifin Corporation
 6035 Parkland Blvd.
 Cleveland, Ohio 44124-4141
 Telephone: (216) 896-3000
 Fax: (216) 896-4000
 www.parker.com

Parker Hannifin Corporation

About Parker Hannifin Corporation

Parker Hannifin is a leading global motion-control company dedicated to delivering premier customer service. A Fortune 500 corporation listed on the New York Stock Exchange (PH), our components and systems comprise over 1,400 product lines that control motion in some 1,000 industrial and aerospace markets. Parker is the only manufacturer to offer its customers a choice of hydraulic, pneumatic, and electromechanical motion-control solutions. Our Company has the largest distribution network in its field, with over 7,500 distributors serving nearly 400,000 customers worldwide.

Parker's Charter

To be a leading worldwide manufacturer of components and systems for the builders and users of durable goods. More specifically, we will design, market and manufacture products controlling motion, flow and pressure. We will achieve profitable growth through premier customer service.

Product Information

North American customers seeking product information, the location of a nearby distributor, or repair services will receive prompt attention by calling the Parker Product Information Center at our toll-free number: 1-800-C-PARKER (1-800-272-7537). In Europe, call 00800-C-PARKER-H (00800-2727-5374).

The Aerospace Group is a leader in the development, design, manufacture and servicing of control systems and components for aerospace and related high-technology markets, while achieving growth through premier customer service.



The Climate & Industrial Controls Group designs, manufactures and markets system-control and fluid-handling components and systems to refrigeration, air-conditioning and industrial customers worldwide.



The Fluid Connectors Group designs, manufactures and markets rigid and flexible connectors, and associated products used in pneumatic and fluid systems.



The Seal Group designs, manufactures and distributes industrial and commercial sealing devices and related products by providing superior quality and total customer satisfaction.



The Hydraulics Group designs, produces and markets a full spectrum of hydraulic components and systems to builders and users of industrial and mobile machinery and equipment.



The Filtration Group designs, manufactures and markets quality filtration and clarification products, providing customers with the best value, quality, technical support, and global availability.



The Automation Group is a leading supplier of pneumatic and electromechanical components and systems to automation customers worldwide.



The Instrumentation Group is a global leader in the design, manufacture and distribution of high-quality critical flow components for worldwide process instrumentation, ultra-high-purity, medical and analytical applications.



Draft #4



Parker Hannifin Corporation
Veriflo Division
250 Canal Boulevard
Richmond, CA 94804-0034
Tel: (510) 235-9590
Fax: (510) 232-7396
<http://www.veriflo.com>

Catalog 4512, 04/05