

aerospace  
climate control  
electromechanical  
filtration  
fluid & gas handling  
hydraulics  
pneumatics  
process control  
sealing & shielding



## SLVD-N

Compact Servo Drive



ENGINEERING YOUR SUCCESS.



**WARNING – USER RESPONSIBILITY**

**FAILURE OR IMPROPER SELECTION OR IMPROPER USE OF THE PRODUCTS DESCRIBED HEREIN OR RELATED ITEMS CAN CAUSE DEATH, PERSONAL INJURY AND PROPERTY DAMAGE.**

- This document and other information from Parker-Hannifin Corporation, its subsidiaries and authorized distributors provide product or system options for further investigation by users having technical expertise.
- The user, through its own analysis and testing, is solely responsible for making the final selection of the system and components and assuring that all performance, endurance, maintenance, safety and warning requirements of the application are met. The user must analyze all aspects of the application, follow applicable industry standards, and follow the information concerning the product in the current product catalog and in any other materials provided from Parker or its subsidiaries or authorized distributors.
- To the extent that Parker or its subsidiaries or authorized distributors provide component or system options based upon data or specifications provided by the user, the user is responsible for determining that such data and specifications are suitable and sufficient for all applications and reasonably foreseeable uses of the components or systems.

<b>Overview .....</b>	<b>5</b>
<b>Technical Characteristics.....</b>	<b>7</b>
Technical Data.....	7
SLVD-N Features .....	7
Electrical Characteristics .....	8
Environmental Characteristics.....	8
Standards and Conformance .....	8
Dimensions .....	9
Connector Layout.....	9
<b>Accessories and Options .....</b>	<b>10</b>
Keypad.....	10
I/O Expansion Module .....	10
Cables.....	10
Network Bridge.....	10
Safety Option .....	10
EtherCAT Fieldbus .....	10
Software .....	11
<b>Order Code.....</b>	<b>12</b>
Compact Servo Drive - SLVD-N .....	12
Accessories .....	12

# Parker Hannifin

- the global leader in motion and control technologies

A world class player on a local stage

## Global Product Design

Parker Hannifin has more than 40 years experience in the design and manufacturing of drives, controls, motors and mechanical products. With dedicated global product development teams, Parker draws on industry-leading technological leadership and experience from engineering teams in Europe, North America and Asia.

## Local Application Expertise

Parker has local engineering resources committed to adapting and applying our current products and technologies to best fit our customers' needs.

## Manufacturing to Meet Our Customers' Needs

Parker is committed to meeting the increasing service demands that our customers require to succeed in the global industrial market. Parker's manufacturing teams seek continuous improvement through the implementation of lean manufacturing methods throughout the process. We measure ourselves on meeting our customers' expectations of quality and delivery, not just our own. In order to meet these expectations, Parker operates and continues to invest in our manufacturing facilities in Europe, North America and Asia.

## Worldwide Manufacturing Locations

### Europe

Littlehampton, United Kingdom  
Dijon, France  
Offenburg, Germany  
Milan, Italy

### Asia

Shanghai, China  
Chennai, India

### North America

Rohnert Park, California  
Irwin, Pennsylvania  
Wadsworth, Ohio  
Charlotte, North Carolina  
New Ulm, Minnesota



Offenburg, Germany

## Local Manufacturing and Support in Europe

Parker provides sales assistance and local technical support through a network of dedicated sales teams and authorized technical distributors throughout Europe.

For contact information, please refer to the Sales Offices on the back cover of this document or visit [www.parker.com](http://www.parker.com)



Milan, Italy



Littlehampton, UK

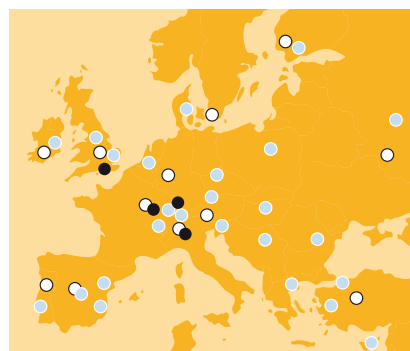

- Manufacturing
- Parker Sales Offices
- Distributors



Dijon, France

# Compact Servo Drive - SLVD-N

## Overview

### Description

SLVD-N is the family of compact digital servo drives for brushless motors which, in addition to positioning applications with trapezoidal profile, electrical shaft, electronic cam, spindle orientation, simulator of stepper motor and torque control, holds a PLC inside able to talk to the most common industrial programming systems, giving a great freedom of use of the inputs and outputs. It also allows the development of additional configurations to the basic features of the drive, such as gains adjustment of the loop in relation to speed or space, torque monitoring used for tools etc.

The SLVD-N range is equipped with a serial interface RS422/RS485 allowing the operator to configure, monitoring, give commands to up to 32 units simultaneously. A CANbus interface is available both in communication mode and in real time mode with SBCCAN, DS301, DS402 protocols.

### Typical applications:

- Packaging machines
- Pick & place systems
- General purpose machines

### Features

- Torque/current/speed control
- Advanced manager of torque limits
- Management of speed windows
- Positioner
- Electric shaft
- Electronic cam
- Controls the motor torque with the addition of speed control
- Virtual master
- Internal PLC - programming according to IEC61131 (option)
- Configurable feedback
- Standard interface: RS422/485, CANopen
- Optional interface: EtherCAT
- Internal braking resistor
- Internal EMC filter for three phase power supply
- Safety: STO function optional



### Technical Characteristics - Overview

<b>Power supply</b>	200...230 VAC single/three phase (±10 %) 50-60 Hz (±5 %) - only TT/TN networks
<b>Control supply</b>	24 VDC (-0/+10 %)
<b>Overload</b>	200 % for 2 s
<b>Operating temperature</b>	0...45 °C
<b>Operating humidity</b>	<85 % non condensing
<b>Altitude</b>	1000 m asl with 1.5 % derating every 100 m, up to 2000 m
<b>Protections</b>	IP20
<b>International standards</b>	CE, UL, cUL

Model	Continuous current [A]	Peak current [A]	Size
SLVD1N	1.25	2.5	1
SLVD2N	2.5	5	
SLVD5N	5	10	
SLVD7N	7	14	
SLVD10N	10	20	2
SLVD15N	15	30	
SLVD17N	17	34	

## Typical Applications

### Industry: Robotics

#### Application: Painting robot

6/7 axes painting robot controlled by the SLVD-N servo drive. Full control of the machine is done with a dedicated motion controller and the remote I/O is managed over CANopen.

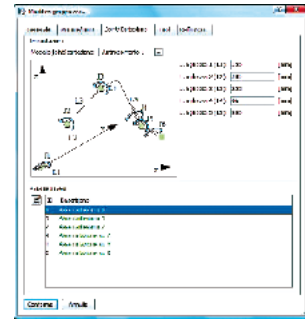

### Industry: Glass Industry

#### Application: Machining Centre

A 4 axis machine (x, y, z, mandrel) executing the following operations: drilling, threading and linear milling on materials of different types. The system comprises of 4 SLVD-N and 4 SMB motors. The control of the machine is via a dedicated motion controller. The remote I/O is controlled with CANopen protocol.

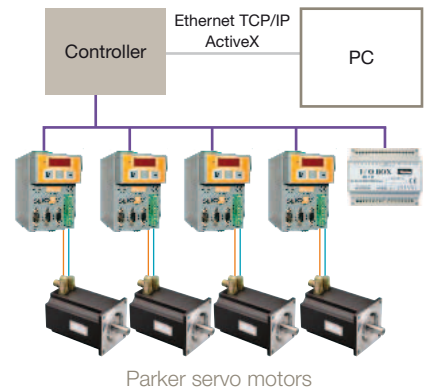

### Industry: Beverage Industry

#### Application: Multi-head bottle capper

A multi-head machine able to cap bottles of different format. Each head, in order to reduce setup time, installs 2 SLVD-Ns, one dedicated to the vertical movement of the head depending on the carousel position and the other dedicated to the capping with preset torque. The machine is made of up to 16 heads with 2 SLVD-Ns each. The control of the machine based to a motion controller. The remoted I/O is controlled with CANopen protocol.

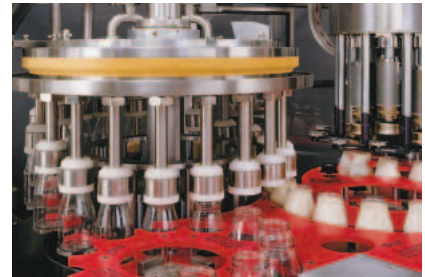

#### Multi-head bottle capper

A multi-head machine to cap bottles of different formats. Each head has 1 SLVD-N dedicated to cap fastening with torque control. The machine is made of up to 32 heads with 1 SLVD-N per head. The control of the machine based on a motion controller. The remote I/O is controlled with CANopen protocol.

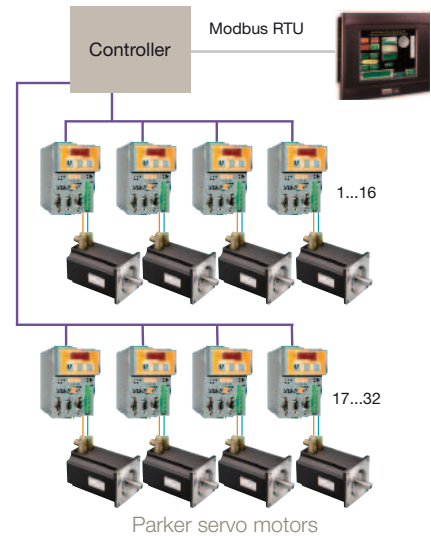



# Technical Characteristics

## Technical Data

Model		SLVD1N	SLVD2N	SLVD5N	SLVD7N	SLVD10N	SLVD15N	SLVD17N	
	Unit								
<b>Input and output characteristic</b>									
Rated input current (FLA)	[Aeff]	1.5	2.99	5.99	8.38	11.97	17.96	20.36	
Rated output current	[Aeff]	1.25	2.5	5	7	10	15	17	
Peak output current (2 s)	[A]	2.5	5	10	14	20	30	34 (30@8 kHz)	
Shaft power	[kW]	0.345	0.7	1.5	2.2	3.0	4.5	5	
Continuous service installed load (power derating)	1ph [kVA]	0.85	1.5	1.5	1.8	3.0	3.3	3.3	
	3ph [kVA]	0.95	1.6	2.3	3	5.25	6.5	6.5	
Continuous service input current (power derating)	1ph [Aeff]	3.8	6.5	6.5	7.8	14.3	14.3	14.3	
	3ph [Aeff]	2.4	4.2	5.9	7.6	13.3	17.2	17.2	
Power stage dissipation	[W]	9.3	19.2	52.0	75.1	100.3	158.3	180	
Switching frequency	[kHz]	4...8						4...8	
Output frequency	[Hz]	0...450							
<b>Dynamic braking and intermediate DC circuit</b>									
Internal DC capacitors (±20 %)	[µF]	680			820	1800			
Braking resistor internal	[Ω]	40					16		
Peak internal braking power to 415 VDC	[kW]	4.3					10.7		
Max continuous external braking power	[kW]	1					2		
Max duty cycle (internal resistance)	[%]	1.20					1.10		

## SLVD-N Features

<b>Feedback</b>	<ul style="list-style-type: none"> <li>• Resolver (SLVD-N)</li> <li>• Encoder (SLVD-NE)</li> <li>• Encoder+Hall (SLVD-NH)</li> </ul>
<b>Auxiliary encoder input</b>	in quadrature
<b>Max frequency encoder input</b>	400 kHz
<b>RS422 encoder simulation output</b>	4...65 000 steps/rev
<b>Max frequency</b>	160 kHz
<b>Serial link</b>	RS422 / RS485
<b>Fieldbus</b>	CAN ISO/DIS11898
<b>Inputs / outputs</b>	<ul style="list-style-type: none"> <li>• 4 digital inputs 0...24 V</li> <li>• 2 digital outputs</li> <li>• 1 differential analog reference ±10 V</li> <li>• 1 differential auxiliary analog input ±10 V</li> <li>• 1 analogue output single ended ±4 V</li> </ul>
<b>Safety technology</b>	STO function optional - category 3 performance level in compliance with UNI EN ISO 13849-1- SIL capability 3 in compliance with CEI EN 61800-5-2, PL=e

## Electrical Characteristics

### Power supply

Model		SLVD-N
	Unit	Control stage
Supply voltage	[VDC]	24 V (-0...+10 %)
Max. ripple	[V <sub>pkpk</sub> ]	Do not go over the range
Current rating of the external power supply	[A]	1
Control electronics dissipation	[W]	15
EMC filter	-	internal
		Power stage
Mains frequency	[Hz]	50...60 ±5 %
Supply voltage (3-phase or 1-phase)	[VAC]	200...230 ±10 % (only for TT, TN mains)
DC voltage range	[VDC]	282...325 ±10 %
EMC filter	-	internal

## Environmental Characteristics

### Ambient conditions

<b>Temperature range</b>	<ul style="list-style-type: none"> <li>Operating temperature: 3K3 class, 0...+45 °C (+32...+113 °F)</li> <li>Storage temperature: 1K4 class, -25 ...+55 °C (-4...+131 °F)</li> <li>Transportation temperature: 2K3 class, -25 ... +70 °C (-13...+158 °F)</li> </ul>
<b>Humidity</b>	<ul style="list-style-type: none"> <li>Operating humidity: 3K3 class, 5...85 % without ice and condensation</li> <li>Storage humidity: 1K3 class, 5...95 % without ice and condensation</li> <li>Transportation humidity: 2K3 class, 95 % a 40 °C</li> </ul>
<b>Altitude (*)</b>	≤1000 m asl (≤3281 feet asl)
<b>Protection degree</b>	IP20 (only in close electric cabinet), UL open type equipment
<b>Pollution degree</b>	2 or lower (no conductive dust allowed)

\* For higher installation altitude, derate the output current by 1.5 % each 100 m up to 2000 m maximum

### Shock and vibration

IEC60068-2-6	Frequency [Hz]	Width [mm]	Acceleration [m/s <sup>2</sup> ]
	10 ≤ f ≤ 57	0.075	-
	57 < f ≤ 150	-	9.81

## Standards and Conformance

<b>Safety standards</b>	<ul style="list-style-type: none"> <li>2006/95/EC: Low voltage directive</li> <li>EN 61800-5-1: Adjustable speed electrical power drive systems - part 5-1: safety requirements, electrical, thermal and energy</li> </ul>
<b>Certification</b>	<ul style="list-style-type: none"> <li>UL: UL508C (USA) Power Conversion Equipment</li> <li>CSA: CSA22.2 Nr. 14-5 (Canada) Power Conversion Equipment</li> </ul>
<b>Electromagnetic compatibility</b>	<ul style="list-style-type: none"> <li>2004/108/EC: EMC directive</li> <li>EN 61800-3: Adjustable speed electrical power drive systems - part 3: EMC requirement and specific test methods</li> </ul>



## Dimensions

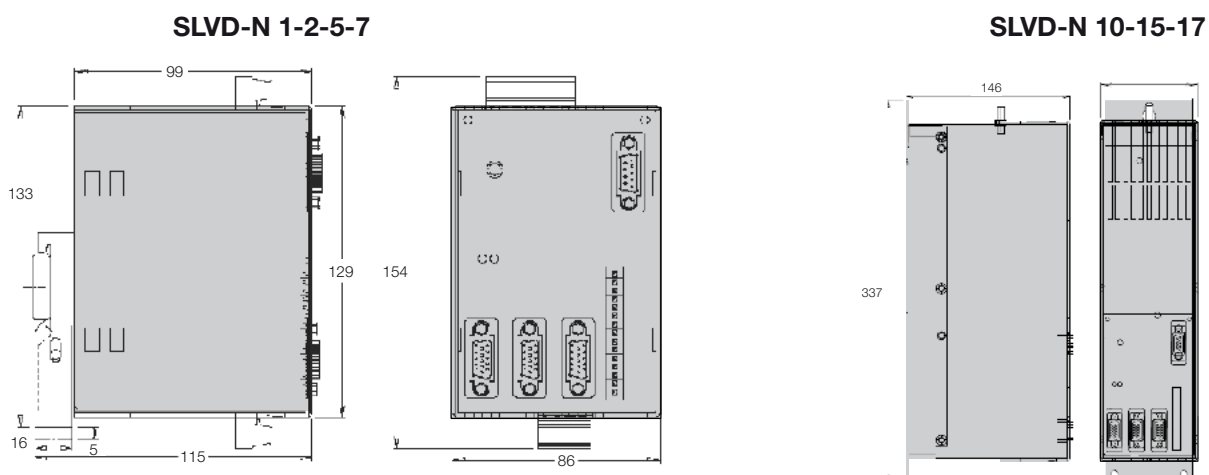

Model	Height [mm]	Width [mm]	Depth [mm]	Weight [kg]
SLVD-N 1-2-5-7	154	86	115	1.1
SLVD-N 10-15-17	337	87	146	3.1

## Connector Layout

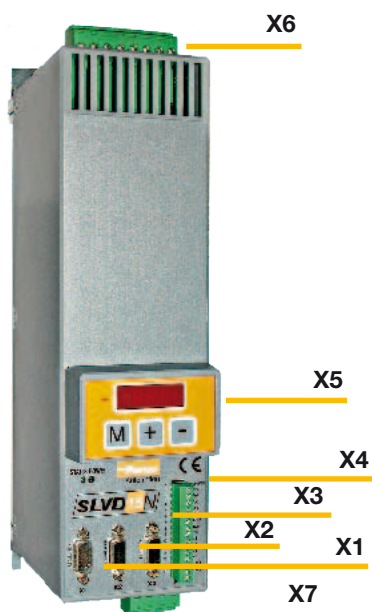

X1	RS422/485 - CAN interface
X2	Encoder input/output
X3	Resolver/encoder configurable input
X4	4 digital inputs 0-24 V 2 digital outputs 1 differential analogue reference $\pm 10$ V 1 differential aux analog input $\pm 10$ V 1 analogue output single ended $\pm 4$ V
X5	Optional board connector (behind the keypad)
X6	Power terminal block
X7	DC bus terminal block

## Accessories and Options

### Keypad

SK158/L <sup>1)</sup>

Easy to use to program the functional data, control the status of the converter and send commands.



### I/O Expansion Module

SK135/S

- 16 in + 8 out
- SBCCAN interface

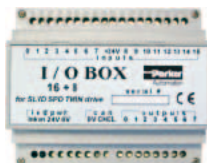

### Cables

- Power and signal cables for resolver, incremental and absolute encoder and SinCos feedback
- Cable to connect a Bridge with several SLVD-N drives



### Network Bridge

Interface protocol:

- DeviceNet
- Profibus DP

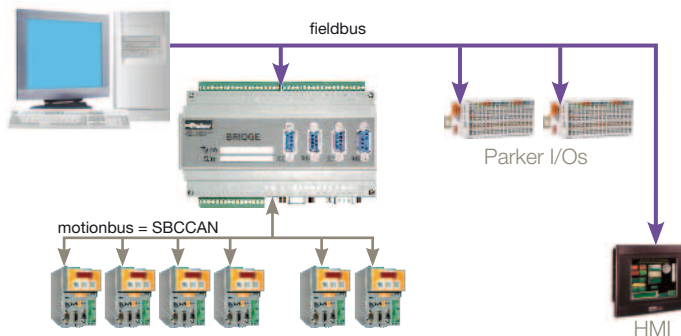

### Safety Option

Option "Safe Torque off" (STO) for all SLVD-N drives available

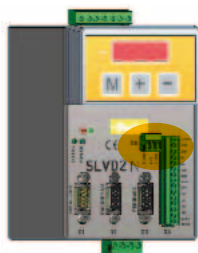

### EtherCAT Fieldbus

Applying industrial standard fieldbus systems enables the SLVD-N to be very versatile.

#### Option EtherCAT (E5, E6):

**Feature:** 1 EtherCAT option for up to 3 SLVD-N (requirement SLVD-N with EtherCAT protocol)



SLVD-N & EtherCAT box (option E5)

<sup>1)</sup> Not in combination with option E5

## Software

### MotionWiz and LogicLab

The free MotionWiz configuration software is available to configure the SLVD-N system with just a few clicks of the mouse. MotionWiz features an easy and "friendly" interface to speed up installation, optimisation and diagnostics procedures. To simplify configuration, MotionWiz shows a typical Windows® environment on the monitor with dialogue windows and toolbars.

MotionWiz permits performing operations in both "on line" mode, directly in the mechanism, and in "off line" mode in remote on the PC. In this case, personalised configuration can be sent to the mechanism subsequently.

To simplify the configuration of systems with a large number of axis but with different cuts and the same operating mode, MotionWiz permits maintaining the same mechanism configuration and only changing the type of selected motor. Inside the MotionWiz configurator is a database containing the data of standard Parker motors.

MotionWiz incorporates "picoPLC", a built-in PLC environment programmable with standard language. PicoPLC allows the external word to communicate with the drive and to execute function sequences. Should the custom application require additional computational resources, an option software environment can be used, programmable with PLC commands according to IEC61131-3.

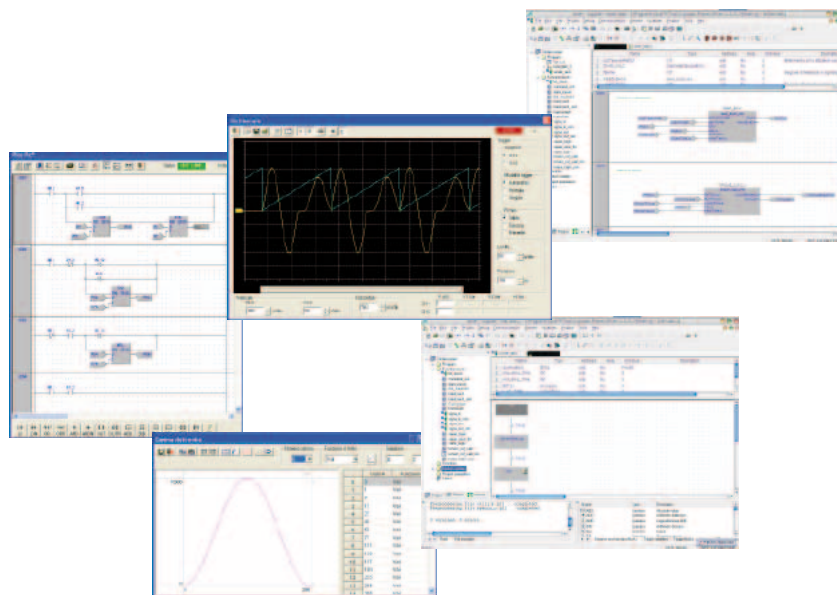

## Order Code

### Compact Servo Drive - SLVD-N

	1	2	3	4	5	6	7	8
Order example	<b>SLVD</b>	<b>1</b>	<b>N</b>	<b>S</b>	<b>E</b>			<b>UL</b>

<b>1 Servo family</b>	<b>SLVD</b>	Compact Digital Servodrive
<b>2 Drive size (nominal current)</b>	<b>1</b>	1 A
	<b>2</b>	2 A
	<b>5</b>	5 A
	<b>7</b>	7 A
	<b>10</b>	10 A
	<b>15</b>	15 A
	<b>17</b>	17 A
<b>3 Version</b>	<b>N</b>	New version
<b>4 Protocol</b>	<b>S</b>	SBCCAN protocol (standard)
	<b>C</b>	CANopen protocol (DS301)
	<b>D</b>	CANopen protocol (DS402)
	<b>E5</b>	EtherCAT protocol (only with optional board E5 or E6 in the bus system)

<b>5 Encoder input</b>	<b>Empty field</b>	Resolver
	<b>E</b>	EnDat/incremental/SinCos encoder input (from motor feedback)
	<b>H</b>	Incremental encoder input with Hall sensor (from motor feedback)
	<b>F</b>	SinCos encoder input
<b>6 Optional boards</b>	<b>Empty field</b>	without optional board
	<b>E5</b>	OP-ETCAT - EtherCAT option (for up to 3 SLVD-N, keypad SK158/L not possible)
	<b>E6</b>	E5 + keypad SK158/L (for up to 3 SLVD-N)
<b>7 Safety</b>	<b>Empty field</b>	without STO
	<b>R</b>	STO (Safe Torque Off function)
<b>8 Firmware review</b>	<b>Empty field</b>	without UL certification
	<b>UL</b>	UL certification (not for all drive sizes available, please contact your Parker partner)

## Accessories

### Communication interface

	1	2
Order example	<b>BRIDGEN</b>	<b>PS</b>

<b>1 Bridge (communication interface)</b>	<b>BRIDGEN</b>	Bridge N (communication interface)
<b>2 Interface</b>	<b>PS</b>	with PROFIBUS DP
	<b>DS</b>	with DeviceNet
	<b>D1S</b>	with DeviceNet "compact"
	<b>DU</b>	with Encoder Input - SBCCAN

### Cables (Bridge - SLVD-N)

	1	2	3	4
Order example	<b>CAVO</b>	<b>BRIDGEX</b>	<b>1</b>	<b>- 2SLVDN</b>

<b>1 Type</b>	<b>CAVO</b>	Cable
<b>2 Product application</b>	<b>BRIDGEX</b>	Connection Bridge - SLVD-N
<b>3 Cable length (length from Bridge to SLVD-N)</b>	<b>1</b>	1 m
	<b>1.5</b>	1.5 m
	<b>2</b>	2 m
<b>4 Number of connections/drives (min. 2, max. 8)</b>	<b>2SLVDN</b>	for 2 SLVD-N
	<b>3SLVDN</b>	for 3 SLVD-N
	<b>4SLVDN</b>	for 4 SLVD-N
	<b>4SLVDN-R</b>	for 4 SLVD-N-R (only 1.5 m)
	<b>8SLVDN</b>	for 8 SLVD-N







# Parker's Motion & Control Technologies

At Parker, we're guided by a relentless drive to help our customers become more productive and achieve higher levels of profitability by engineering the best systems for their requirements. It means looking at customer applications from many angles to find new ways to create value. Whatever the motion and control technology need, Parker has the experience, breadth of product and global reach to consistently deliver. No company knows more about motion and control technology than Parker. For further info call 00800 27 27 5374.



## AEROSPACE

### Key Markets

- Aircraft engines
- Business & general aviation
- Commercial transports
- Land-based weapons systems
- Military aircraft
- Missiles & launch vehicles
- Regional transports
- Unmanned aerial vehicles

### Key Products

- Flight control systems & components
- Fluid conveyance systems
- Fluid metering delivery & atomization devices
- Fuel systems & components
- Hydraulic systems & components
- Inert nitrogen generating systems
- Pneumatic systems & components
- Wheels & brakes



## CLIMATE CONTROL

### Key Markets

- Agriculture
- Air conditioning
- Food, beverage & dairy
- Life sciences & medical
- Precision cooling
- Processing
- Transportation

### Key Products

- CO<sup>2</sup> controls
- Electronic controllers
- Filter driers
- Hand shut-off valves
- Hose & fittings
- Pressure regulating valves
- Refrigerant distributors
- Safety relief valves
- Solenoid valves
- Thermostatic expansion valves



## ELECTROMECHANICAL

### Key Markets

- Aerospace
- Factory automation
- Food & beverage
- Life science & medical
- Machine tools
- Packaging machinery
- Paper machinery
- Plastics machinery & converting
- Primary metals
- Semiconductor & electronics
- Textile
- Wire & cable

### Key Products

- AC/DC drives & systems
- Electric actuators
- Controllers
- Gantry robots
- Gearheads
- Human machine interfaces
- Industrial PCs
- Inverters
- Linear motors, slides and stages
- Precision stages
- Stepper motors
- Servo motors, drives & controls
- Structural extrusions



## FILTRATION

### Key Markets

- Food & beverage
- Industrial machinery
- Life sciences
- Marine
- Mobile equipment
- Oil & gas
- Power generation
- Process
- Transportation

### Key Products

- Analytical gas generators
- Compressed air & gas filters
- Condition monitoring
- Engine air, fuel & oil filtration & systems
- Hydraulic, lubrication & coolant filters
- Process, chemical, water & microfiltration filters
- Nitrogen, hydrogen & zero air generators



## FLUID & GAS HANDLING

### Key Markets

- Aerospace
- Agriculture
- Bulk chemical handling
- Construction machinery
- Food & beverage
- Fuel & gas delivery
- Industrial machinery
- Mobile
- Oil & gas
- Transportation
- Welding

### Key Products

- Brass fittings & valves
- Diagnostic equipment
- Fluid conveyance systems
- Industrial hose
- PTFE & PFA hose, tubing & plastic fittings
- Rubber & thermoplastic hose & couplings
- Tube fittings & adapters
- Quick disconnects



## HYDRAULICS

### Key Markets

- Aerospace
- Aerial lift
- Agriculture
- Construction machinery
- Forestry
- Industrial machinery
- Mining
- Oil & gas
- Power generation & energy
- Truck hydraulics

### Key Products

- Diagnostic equipment
- Hydraulic cylinders & accumulators
- Hydraulic motors & pumps
- Hydraulic systems
- Hydraulic valves & controls
- Power take-offs
- Rubber & thermoplastic hose & couplings
- Tube fittings & adapters
- Quick disconnects



## PNEUMATICS

### Key Markets

- Aerospace
- Conveyor & material handling
- Factory automation
- Food & beverage
- Life science & medical
- Machine tools
- Packaging machinery
- Transportation & automotive

### Key Products

- Air preparation
- Compact cylinders
- Field bus valve systems
- Grippers
- Guided cylinders
- Manifolds
- Miniature fluidics
- Pneumatic accessories
- Pneumatic actuators & grippers
- Pneumatic valves and controls
- Rodless cylinders
- Rotary actuators
- Tie rod cylinders
- Vacuum generators, cups & sensors



## PROCESS CONTROL

### Key Markets

- Chemical & refining
- Food, beverage & dairy
- Medical & dental
- Microelectronics
- Oil & gas
- Power generation

### Key Products

- Analytical sample conditioning products & systems
- Fluoropolymer chemical delivery fittings, valves & pumps
- High purity gas delivery fittings, valves & regulators
- Instrumentation fittings, valves & regulators
- Medium pressure fittings & valves
- Process control manifolds



## SEALING & SHIELDING

### Key Markets

- Aerospace
- Chemical processing
- Consumer
- Energy, oil & gas
- Fluid power
- General industrial
- Information technology
- Life sciences
- Military
- Semiconductor
- Telecommunications
- Transportation

### Key Products

- Dynamic seals
- Elastomeric o-rings
- EMI shielding
- Extruded & precision-cut, fabricated elastomeric seals
- Homogeneous & inserted elastomeric shapes
- High temperature metal seals
- Metal & plastic retained composite seals
- Thermal management

# Parker Worldwide

## Europe, Middle East, Africa

**AE – United Arab Emirates,**  
Dubai

Tel: +971 4 8127100  
parker.me@parker.com

**AT – Austria,** Wiener Neustadt

Tel: +43 (0)2622 23501-0  
parker.austria@parker.com

**AT – Eastern Europe,** Wiener  
Neustadt

Tel: +43 (0)2622 23501 900  
parker.easteurope@parker.com

**AZ – Azerbaijan,** Baku

Tel: +994 50 2233 458  
parker.azerbaijan@parker.com

**BE/LU – Belgium,** Nivelles

Tel: +32 (0)67 280 900  
parker.belgium@parker.com

**BY – Belarus,** Minsk

Tel: +375 17 209 9399  
parker.belarus@parker.com

**CH – Switzerland,** Etoy

Tel: +41 (0)21 821 87 00  
parker.switzerland@parker.com

**CZ – Czech Republic,** Klecany

Tel: +420 284 083 111  
parker.czechrepublic@parker.com

**DE – Germany,** Kaarst

Tel: +49 (0)2131 4016 0  
parker.germany@parker.com

**DK – Denmark,** Ballerup

Tel: +45 43 56 04 00  
parker.denmark@parker.com

**ES – Spain,** Madrid

Tel: +34 902 330 001  
parker.spain@parker.com

**FI – Finland,** Vantaa

Tel: +358 (0)20 753 2500  
parker.finland@parker.com

**FR – France,** Contamine s/Arve

Tel: +33 (0)4 50 25 80 25  
parker.france@parker.com

**GR – Greece,** Athens

Tel: +30 210 933 6450  
parker.greece@parker.com

**HU – Hungary,** Budapest

Tel: +36 1 220 4155  
parker.hungary@parker.com

**IE – Ireland,** Dublin

Tel: +353 (0)1 466 6370  
parker.ireland@parker.com

**IT – Italy,** Corsico (MI)

Tel: +39 02 45 19 21  
parker.italy@parker.com

**KZ – Kazakhstan,** Almaty

Tel: +7 7272 505 800  
parker.easteurope@parker.com

**NL – The Netherlands,** Oldenzaal

Tel: +31 (0)541 585 000  
parker.nl@parker.com

**NO – Norway,** Asker

Tel: +47 66 75 34 00  
parker.norway@parker.com

**PL – Poland,** Warsaw

Tel: +48 (0)22 573 24 00  
parker.poland@parker.com

**PT – Portugal,** Leca da Palmeira

Tel: +351 22 999 7360  
parker.portugal@parker.com

**RO – Romania,** Bucharest

Tel: +40 21 252 1382  
parker.romania@parker.com

**RU – Russia,** Moscow

Tel: +7 495 645-2156  
parker.russia@parker.com

**SE – Sweden,** Spånga

Tel: +46 (0)8 59 79 50 00  
parker.sweden@parker.com

**SK – Slovakia,** Banská Bystrica

Tel: +421 484 162 252  
parker.slovakia@parker.com

**SL – Slovenia,** Novo Mesto

Tel: +386 7 337 6650  
parker.slovenia@parker.com

**TR – Turkey,** Istanbul

Tel: +90 216 4997081  
parker.turkey@parker.com

**UA – Ukraine,** Kiev

Tel +380 44 494 2731  
parker.ukraine@parker.com

**UK – United Kingdom,** Warwick

Tel: +44 (0)1926 317 878  
parker.uk@parker.com

**ZA – South Africa,** Kempton Park

Tel: +27 (0)11 961 0700  
parker.southafrica@parker.com

## North America

**CA – Canada,** Milton, Ontario

Tel: +1 905 693 3000

**US – USA,** Cleveland

Tel: +1 216 896 3000

## Asia Pacific

**AU – Australia,** Castle Hill

Tel: +61 (0)2-9634 7777

**CN – China,** Shanghai

Tel: +86 21 2899 5000

**HK – Hong Kong**

Tel: +852 2428 8008

**IN – India,** Mumbai

Tel: +91 22 6513 7081-85

**JP – Japan,** Tokyo

Tel: +81 (0)3 6408 3901

**KR – South Korea,** Seoul

Tel: +82 2 559 0400

**MY – Malaysia,** Shah Alam

Tel: +60 3 7849 0800

**NZ – New Zealand,** Mt Wellington

Tel: +64 9 574 1744

**SG – Singapore**

Tel: +65 6887 6300

**TH – Thailand,** Bangkok

Tel: +662 186 7000-99

**TW – Taiwan,** Taipei

Tel: +886 2 2298 8987

## South America

**AR – Argentina,** Buenos Aires

Tel: +54 3327 44 4129

**BR – Brazil,** Sao Jose dos Campos

Tel: +55 800 727 5374

**CL – Chile,** Santiago

Tel: +56 2 623 1216

**MX – Mexico,** Apodaca

Tel: +52 81 8156 6000

We reserve the right to make technical changes. The data correspond to the technical state at the time of printing.  
© 2011 Parker Hannifin Corporation.  
All rights reserved.

192-141100N4

October 2011



### EMEA Product Information Centre

Free phone: 00 800 27 27 5374

(from AT, BE, CH, CZ, DE, DK, EE, ES, FI, FR, IE, IL,  
IS, IT, LU, MT, NL, NO, PL, PT, RU, SE, SK, UK, ZA)

### US Product Information Centre

Toll-free number: 1-800-27 27 537

www.parker.com

Your local authorized Parker distributor