

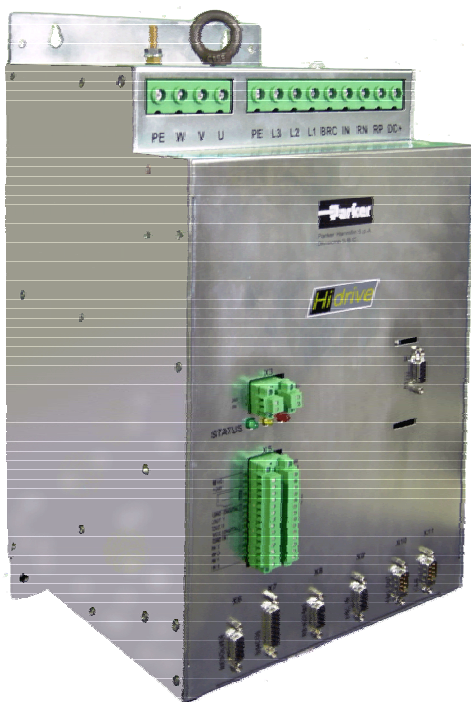

HID

Quick installation guide



MI HI 02 08/07 E
August 2007
(software rel. 10)



SAFETY INSTRUCTIONS**General information**

Only persons who are qualified and trained for the use and operation of the equipment may work on this equipment or within its proximity. The persons are qualified if they have sufficient knowledge of the assembly, transportation, installation and operation of the equipment as well as an understanding of all warnings and precautionary measures noted in these instructions. The user must also observe local safety regulations. Before installing and commissioning the drive, read carefully this documentation and strictly observe all technical, safety and wiring information, including identifying labels placed on the drive (ratings). In case of doubt contact the Parker Hannifin service centre. Drives are to be intended as components for use in machine or systems. Therefore they can be used only in machine or systems that are in compliance with the low voltage directive 73/23/CEE (modified by 93/68/CEE) and with the electro-magnetic compatibility directive 89/336/CEE. Electronic equipments are generally not “fail-safe” components. Therefore the machine manufacturers should carry out a risk analysis for the whole machine in order to ensure that moving parts (motors) cannot bring personal injury in case of failures of electronic devices.

Safety instructions for transportation and storage

The ambient conditions given in the product documentation must be observed for transportation and storage (temperature, humidity, mechanical stress and aggressive atmosphere). Drives contain components sensitive to electrostatic charges which can be damaged by inappropriate handling. Therefore during installation / removal of drives, provide the necessary safety precautions against electrostatic discharges (discharge electrostatic charges of the human body before touching the drive, always place the drive above conductive plates and avoid touching it with insulating material like synthetic fibres, polymeric materials etc...)

Risk of injury by incorrect handling ! Incorrect handling of the equipment may cause severe personal injury. Use appropriate tools for transportation, lifting, handling and mounting. Wear appropriate clothing for accident-prevention (safety shoes, safety glasses, safety gloves, etc...).

Safety instructions for commissioning

The high voltages inside the drive imply risk of electric shock. Make sure that drive and motor are properly grounded accordingly to national regulations. Furthermore the drive, before switching it on, must be closed in a protective cabinet in order to avoid direct contact with accessible live parts. Only qualified and trained personnel is allowed to perform installation and commissioning, using appropriate tools and following the safety precautions given in this instruction. Make sure that supply voltage has been switched off before installing and wiring. Drives are only allowed to be operated on TT, TN grounded industrial mains having maximum 480V+10% line to line rms voltage, as specified in the user manual. Do not directly install the drive on ungrounded (IT) or asymmetrically grounded mains. In case of ungrounded mains, coupling with Dyn transformer with grounded secondary circuit is necessary. Refer to drive technical data and wiring instruction. All the components used in the cabinet in which the drive is installed, (cables, contactors, inductors and transformers, fuses, etc...), and the connected motor, must be in compliance with the specification given in the product documentation, in addition to national regulations. Make sure that the maximum temperature inside the cabinet does not exceed 45°C (113°F). If necessary, use an appropriate air conditioning. The size and temperature rating of wires and cables used for connecting the drive must be in compliance with the specification given in the instruction manual (see NEC 310-16 for USA). Use also the specified tightening torque. Make sure about the correct drive-motor matching: voltage and current ratings must be compatible.

The user is responsible for over-current and short circuit protection of the drive. Read carefully the specification given in the user manual.

Safety instructions for operation

High voltage ! Risk of electric shock ! Danger of life ! All live parts must be protected against direct contact. The drive must be closed inside a cabinet before switching it on. Working on power live parts (terminals) must be conducted with the drive switched-off. Dangerous voltages may be present at power terminals even after the supply has been switched off and the motor stopped. Make sure the equipment cannot be switched on unintentionally. Wait at least 6 minutes before working on live parts after the unit has been switched-off. The drive and the motor must be permanently connected to earth accordingly to the connection diagram, even for brief measurements or tests.

High leakage current ! Risk of electric shock ! Danger of life ! Earth leakage current during operation may exceed 3,5 mA AC or 10mA DC. Earth connection must be permanent : use copper wire having a minimum size of 10mm² throughout all the length. Before switching the equipment on, make sure that all devices, including the motor, are permanently connected to earth, even for brief test or measurements, as shown in the wiring diagrams. Otherwise high voltages may appear on equipment conductive surfaces with danger of electrical shock. Always refer to current local regulations for grounding. For installation within European Community refer to EN61800-5-1 product standard, section 4.2.5.4.2. For installation in the USA refer to NEC (National Electric Code) and NEMA (National Electric Manufacturers Association). The product installation should always comply with the above said standards.

Hot surfaces ! Danger of injury ! Danger of burns ! Some external surfaces of the equipment and same internal part may reach very high temperatures. Danger of burn and injury if touching these parts.

After switching the equipment , wait at least 15 minutes to allow it to cool before touching it.

Dangerous movements ! Danger of life !

In order to prevent personal injury due to unintended dangerous motor movements, pay the maximum attention and work on the machine with a qualified and tested safety system.

Compatibility with RCD devices

The use of RCD (Residual Current Devices) is strongly not recommended. If the use of RCD is mandatory, use type B only (for DC and AC prospective earth current). Set the trip level at 300mA (fire protection level) or more. Setting the trip level at 30mA (protection level against direct contact) is possible only using time-delayed RCD and low leakage current EMC filters, but in any case the drives are not guaranteed to operate with 30mA trip level.

Applicable standards: Safety

73/23/CEE directive mod. by 93/68/CEE	Low voltage directive
EN 50178	Electronic equipment for use in power installations
EN 60204-1	Safety of machinery – Electrical equipment of machines – Part 1: General requirements
EN 61800-2	Adjustable speed electrical power drive systems – Part 2: General requirements – Rating specifications for voltage adjustable frequency a.c. power drive systems
EN 61800-5-1	Adjustable speed electrical power drive systems – safety requirements, thermal and energy
UL508C	(USA) Power Conversion Equipment
CSA22.2 Nr. 14-05	(Canada) Power Conversion Equipment

Applicable standards: Electromagnetic Compatibility (Immunity/Emission)

89/336/CEE directive	EMC directive
EN 61800-3	Adjustable speed electrical power drive systems. Part 3 : EMC product standard including specific test method

The drives are to be intended as components to be used in a second environment (industrial environment) and category C3, together with specific EMC filters and installed accordingly to the recommendation given in the user manual. When used in the first environment (residential / commercial environment), drives may produce radio-frequency interference dangerous for other equipments : additional filtering measures must be implemented by the user.

Materials and disposal

Electrolytic capacitor contain electrolyte and printed circuit boards contain lead, both of which are classified as hazardous waste and must be removed and handled according to local regulations. The S.B.C. division of the Parker Hannifin Company, together with local distributors and in accordance with EU standard 2002/96/EC, undertakes to withdraw and dispose of its products, fully respecting environmental considerations.



This symbol is an invitation to refer to the more detailed information in the integral version of the operator's manual attached to the supply or which can be downloaded from www.sbcelettronica.com

1 HARDWARE SPECIFICATIONS

	Unit	HID2	HID5	HID8	HID10	HID16	HID25	HID35	HID45	HID75	HID100	HID130	
Rated output current	Arms	2	5	8	10	16	25	35	45	75	100	130	
Peak output current (2 sec)	Arms	4	10	16	20	32	50	70	90	135 (3sec)	180 (3sec)	234 (3sec)	
Continuous service installed load	kVA	1,4	3,5	5,6	6,9	11,2	17,5	22,8	28,5	53	70	91	
Power stage dissipation	W	30	75	120	140	220	350	490	540	890	1050	1300	
Switching frequency (selectable)	kHz	8-16	8-16	-	-	-	-	-	-	-	-	-	
Default switching frequency	kHz	8	8	8	4	8	8	4	4	4	4	4	
Current derating with $f_{sw} > f_{default}$	p.u.	0,7		-		-		-		-		-	
Current derating with $V_{main} > 440V\sim$	p.u.	0,9				0,9		-		0,9			
Output frequency	Hz	0 - 500				0 - 500		0 - 500		0 - 400			
Internal fan capacity	m ³ /h	32	47	63	63	168		260	272	459	459	459	
Braking resistor	ohm	200	90	75	75	40	27	13	13 (min)	10 (min)	10 (min)	10 (min)	
Continuous internal braking power	W	75	75	120	120	180	180	400	20k (max)	25k (max)	25k (max)	25k (max)	
Braking power peak 790Vdc	W sec	3120 1	6935 0,7	8320 0,5	8320 0,5	15600 0,2	23115 0,15	48000 0,1	48000	62400	62400	62400	
DC circuit capacity (±20%)	µF	195	390	390	390	585		1800	3150	5000	5000	5000	
Continuous power	W	See diagrams									-		
Continuous power @400V~	kW	-							41	55	72		
Braking threshold	Vdc	795 – 770 (-0V ... +20V)							790 – 770				
Overvoltage level	Vdc	870							870				
Undervoltage level	Vdc	70% * $\sqrt{2}$ * V_{mains}							400 - 440				
EMC filter	-	internal				external		external		internal			
Fan supply voltage	V~	-				-		-		230 ±10% (1ph, 50/60 Hz)			
Fan power	W	-				-		-		140			

2 INSTALLATION

2.1 Identification

HID	Servodrive series		
X	ATEX type drive		
2	Drive size (nominal current, up to 3 digits: 2, 5, 8, 10, 16, 25, 35, 45, 75, 100, 130)		
S	SBC CAN protocol (standard)		
D	CANopen protocol (DS402)		
S	Second encoder input for SinCos signals – 1 V_{pp}		
E	Second encoder input for quadrature digital signals – RS422		
H	Second encoder input for quadrature digital signals + Hall sensor signals		
Y1	Slot N. 1	<i>Code optional boards:</i> P = profibus DP - P I = I/O 8DI+8DO -I E1 = Powerlink (n.a.) E2 = Sercos 3 (n.a.) E3 = CIP (n.a.) E4 = Profinet (n.a.) E5 = Ethercat (n.a.)	S = Sercos D = Devicenet (n.a.) C1 = Robox board up to 1,5 axis (with CANopen DS402) [in 3 Slot] C2 = Robox board up to 4 axis (with CANopen DS402) [su 3 Slot] C3 = Robox board up to 32 axis (with CANopen DS402) [su 3 Slot] C4 = Robox board up to TBD (with CANopen DS402) (n.a.) [in 3 Slot] C5 = Robox board up to TBD (with CANopen DS402) (n.a.) [in 3 Slot] C6 = Robox board up to TBD (with CANopen DS402) (n.a.) [in 3 Slot]
Y2	Slot N. 2		
Y3	Slot N. 3		
R	Internal safety relay		
M	Memory area for ritentive variables		

2.2 Assembly



Do not install in hazardous environments.

All dimensions in mm.
Tolerance ±1,5 mm.

The rear supporting plate features special reamed holes (see illustration).

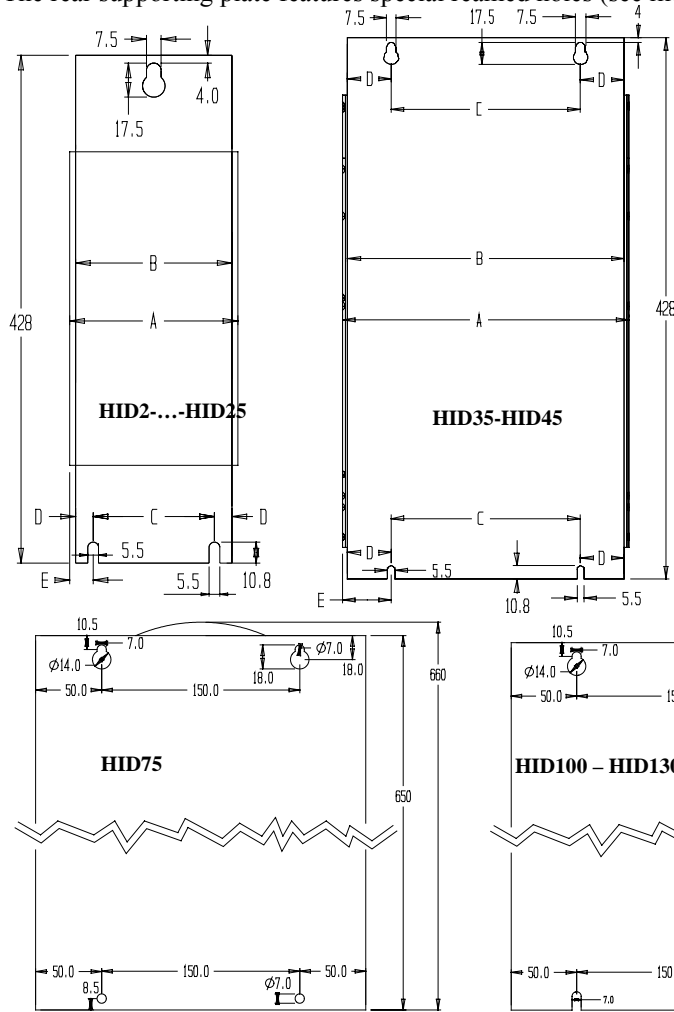

	HID2- HID5- HID8	HID16- HID25	HID35- HID45
A – frame width	87mm	122mm	227mm
B – plate width	80mm	115mm	219mm
C – spacing	62mm	62mm	150mm
D	9mm	26,5mm	34,5mm
E	12mm	30mm	38,5mm

Characteristics	Description
Storage temperature	-20°C ÷ +65°C (-4°F ÷ 149°F)
Room temperature	0°C ÷ 45°C (32°F ÷ 113°F)
Room humidity	< 85 %
Max installation altitude	1000 m asl
Degree of protection	IP20
Degree of pollution	2 or below

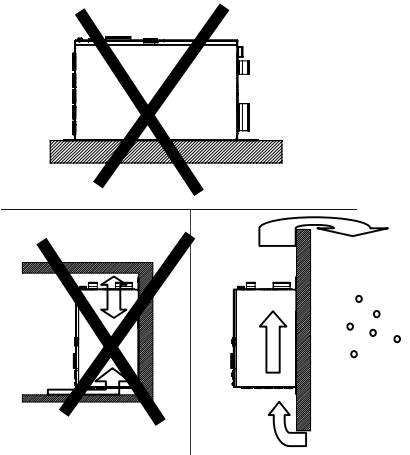

• FIT IN VERTICAL POSITION (power terminal board at top).



• To ensure drive cooling, leave a free space above, below and in front of at least 100 mm. The illustration shows how hot air cooling must be done in an external environment, to avoid damage caused by the formation of condensation.



• The flow of air entering the converter must not come from or pass through other heat source parts.



• Fit a suitable ventilation filter inside the switchboard.

2.3 Dimensioni

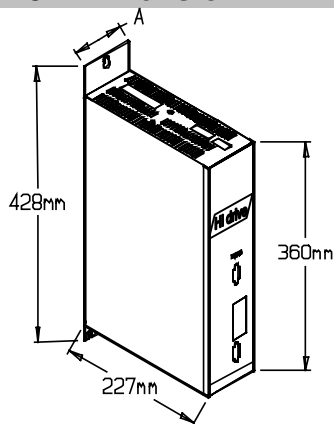

	HID2 HID5 HID8	HID16 HID25	HID35 HID45
A	87mm	122mm	227mm
mass	5,8kg	8,5kg	16kg

	HID75	HID100	HID130
Y	320mm	365mm	365mm
Z	660mm	720mm	720mm
mass	40 kg	59 kg	59 kg

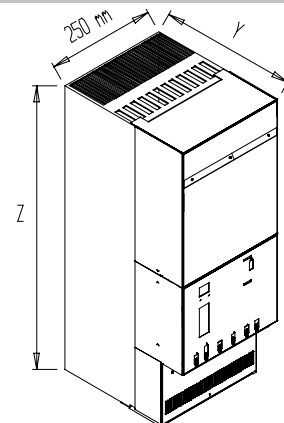

3 WIRING CONNECTIONS

3.1 Protection devices

The drive has no protections against short circuits and overload on the mains side.

The user is responsible for short circuit and overload the protection as follows :

Model	HID2	HID5	HID8	HID10	HID16	HID25	HID35	HID45	HID75	HID100	HID130
Fuse size on AC power supply network (delayed)	6A	10A	16A	16A	20A	50A	50A	75A	110A	175A	200A
Fuse size on VDC control power supply	3.15A fast										

A thermo-magnetic switch can be used instead of fuses with the same effectiveness, but not in installations with UL standard. For UL compliant installations, use ultra-fast fuses accordingly to UL standard (RC, JFHR2).

See the following table:

Model	HID2	HID5	HID8-HID10	HID16	HID25
Mains AC (3)	Bussmann FWP10A14F Ferraz-Shawmut A70P10-1	Bussmann FWP20A14F Ferraz-Shawmut A70P20-1	Bussmann FWP30A14F Ferraz-Shawmut A70P30-1	Bussmann FWP-50B Ferraz-Shawmut A70P50-4	Bussmann FWP-60B Ferraz-Shawmut A70P60-4
Brake resistor (2)	Bussmann FWP10A14F Ferraz-Shawmut A70P10-1	Bussmann FWP20A14F Ferraz-Shawmut A70P20-1	Bussmann FWP20A14F Ferraz-Shawmut A70P30-1	Bussmann FWP30A14F Ferraz-Shawmut A70P30-1	Bussmann FWP-35B Ferraz-Shawmut A70P35-1
DC Bus (2)	Bussmann FWP10A14F Ferraz-Shawmut A70P10-1	Bussmann FWP20A14F Ferraz-Shawmut A70P20-1	Bussmann FWP30A14F Ferraz-Shawmut A70P30-1	Bussmann FWP-50B Ferraz-Shawmut A70P50-4	Bussmann FWP-60B Ferraz-Shawmut A70P60-4
Model	HID35	HID45	HID75	HID100	HID130
Mains AC (3)	Bussmann FWP-80B Ferraz-Shawmut A70P80-4	Bussmann FWP-100B Ferraz-Shawmut A70P100-4	Bussmann FWP125A Ferraz-Shawmut A70P125-4	Bussmann FWP200A Ferraz-Shawmut A70P200-4	Bussmann FWP225A Ferraz-Shawmut A70P225-4
Brake resistor (2)	Bussmann FWP-80B Ferraz-Shawmut A70P80-4	Bussmann FWP-80B Ferraz-Shawmut A70P80-1	Bussmann FWP-80B Ferraz-Shawmut A70P80-4	Bussmann FWP-100B Ferraz-Shawmut A70P100-4	Bussmann FWP-100B Ferraz-Shawmut A70P100-4
DC Bus (2)	Bussmann FWP-80B Ferraz-Shawmut A70P80-4	Bussmann FWP-100B Ferraz-Shawmut A70P100-4	Bussmann FWP175 Ferraz-Shawmut A70P175-4	Bussmann FWP250 Ferraz-Shawmut A70P250-4	Bussmann FWP300 Ferraz-Shawmut A70P300-4

3.2 Wiring harness

Il tipo di cavo per posa mobile o fissa deve essere scelto in base all'applicazione.

Per la sezione del cavo vedere la tabella seguente:

Model		HID2	HID5	HID8	HID10	HID16	HID25
MOTOR (X2)	Section	1.5mm ² (AWG14)	1.5mm ² (AWG14)	2.5mm ² (AWG12)	2.5mm ² (AWG12)	4mm ² (AWG8)	6mm ² (AWG8)
	Tightening torque	0.5 – 0.6 Nm (M3)				1.2 Nm (M4)	
NETWORK (X1)	Section	1.5mm ² (AWG14)	2.5mm ² (AWG12)	2.5mm ² (AWG12)	2.5mm ² (AWG12)	4mm ² (AWG8)	6mm ² (AWG8)
	Tightening torque	0.5 – 0.6 Nm (M3)				1.2 Nm (M4)	
Signal (X5)	Section	0.22 ÷ 1 mm ² (AWG16)					
	Tightening torque	0.22 – 0.25 Nm (M2)					
Stationary brake (X3)	Section	1 mm ² (AWG16)					
	Tightening torque	0.5 – 0.6 Nm (M3)					
Max. motor cable length	60 m						
Max cable capacity	< 150 pF/m						

Model		HID35	HID45	HID75	HID100	HID130
MOTOR	Section	10mm ² (AWG6)	10mm ² (AWG6)	25÷50mm ² (AWG3-4)	35÷95mm ² (AWG1)	35÷95mm ² (AWG2/0)
	Tightening torque	2.5 Nm (M5)		6 ÷ 8 Nm	15 ÷ 20 Nm	
NETWORK	Section	10mm ² (AWG6)	10mm ² (AWG6)	25÷50mm ² (AWG4)	35÷95mm ² (AWG1)	35÷95mm ² (AWG2/0)
	Tightening torque	2.5 Nm (M5)		6 ÷ 8 Nm	15 ÷ 20 Nm	
External braking resistor	Section	10÷25mm ² (AWG6...AWG4)		25÷50mm ² (AWG8)	6÷8mm ² (AWG8)	6÷8mm ² (AWG8)
	Tightening torque	2.5 Nm (M5)		6 ÷ 8 Nm	0.7 Nm	
Signal (X5)	Section	0.22 ÷ 1 mm ² (AWG16)				0.22 ÷ 1 mm ² (AWG16)
	Tightening torque	0.22 – 0.25 Nm (M2)		0.22 – 0.25 Nm (M2)		
Stationary brake (X3)	Section	1mm ² (AWG16)				
	Tightening torque	0.22 – 0.25 Nm (M2)				
Fan supply	Section	-	-	-	2,5mm ² (AWG12)	
	Tightening torque	-	-	-	0.7 Nm	
Max. motor cable length	60 m		50 m / 300 m with inductance			
Max cable capacity	< 150 pF/m					

All signal cables must have a minimum section of 0.22 mm². The cables used for analog signals must be shielded twisted pairs. The resolver cable must consist of 4 individually shielded twisted pairs protected by a shield. The conductor-conductor capacity for the length used cannot exceed 10 nF and the section cannot be less than 0.22 mm². The maximum length is 60 m. The motor cable must be shielded. Shielded cables are also recommended for digital inputs and outputs.

For UL compliant installations, use only stranded copper wire rated for 75°C. Use only appropriate crimping tools to fix terminal lugs. The conductors ampacity shall be 125% of the rated current accordingly to NEC 310-16.

3.3 Connector layout

HID2-...-HID25

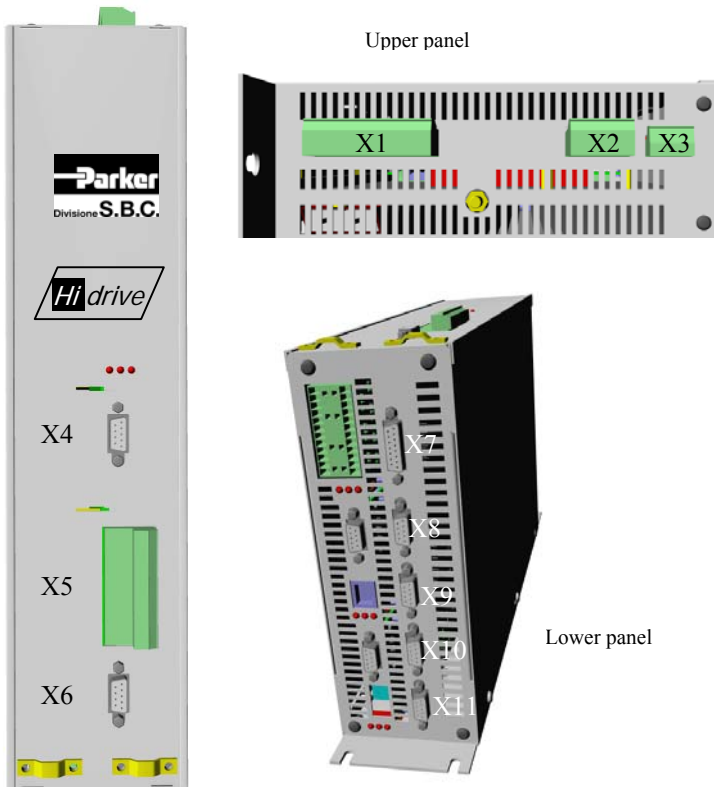

Front panel

HID35-HID45

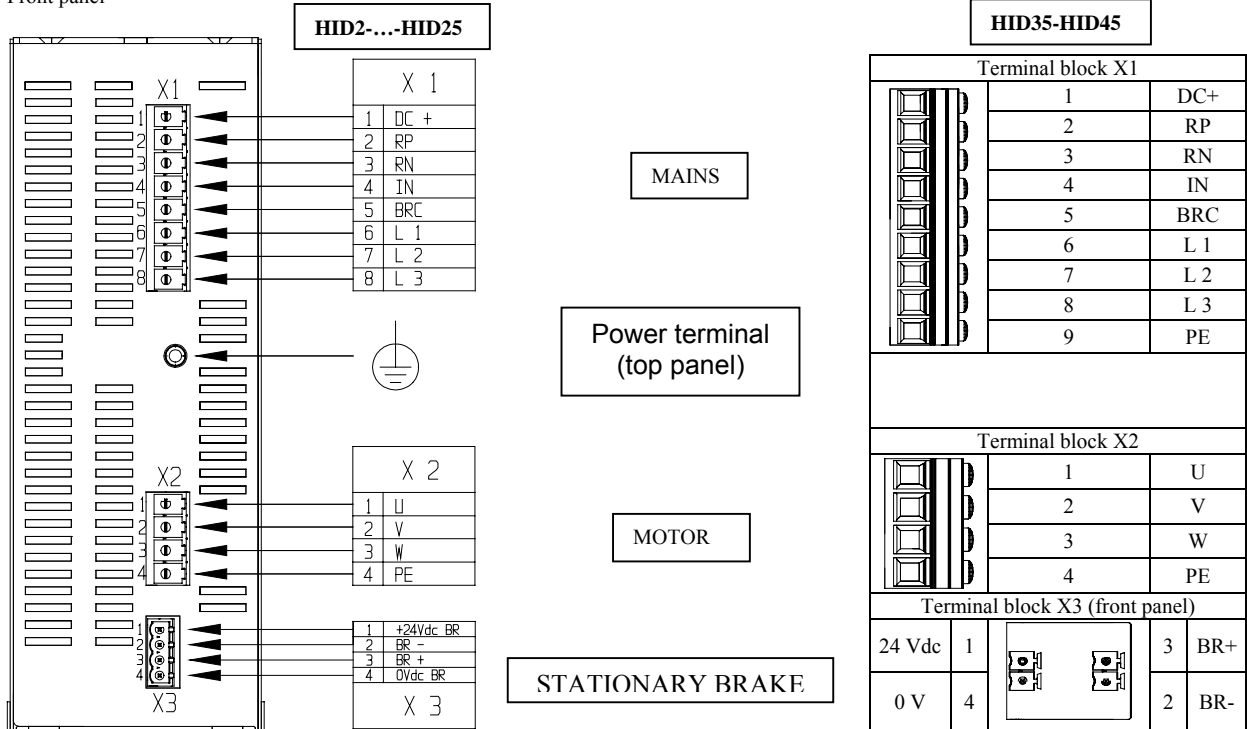
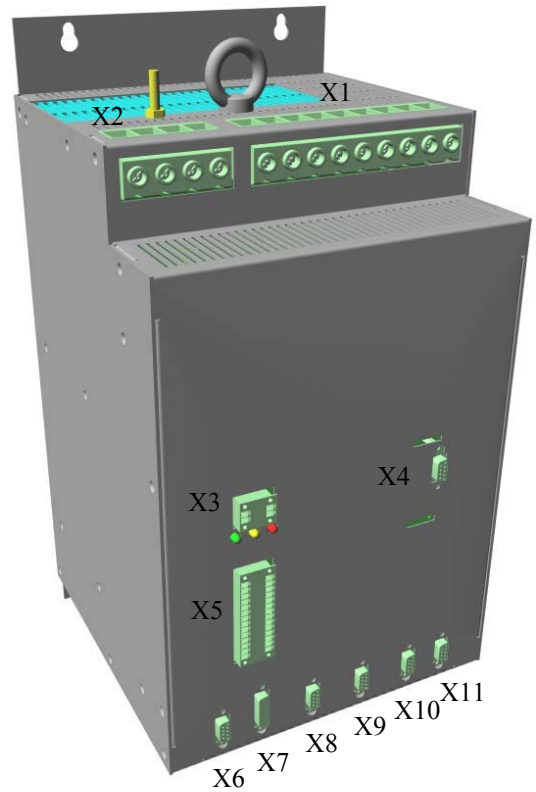

The converter is equipped with 3 led indicators.

When power is applied to the drive (24 VDC), if the drive's electronics is working, the yellow and green leds come on. The third led (red) provides converter status information as listed below:

- **if it is off**, the converter is shut off without active alarms.
- **if it is on**, the converter is enabled. the drive is in RUN mode
- **if it blinks with a pause after two series of blinks**, the converter is disabled and an alarm is active. The active alarm can be identified by counting the number of blinks between the two pauses.
- **if it blinks quickly and continuously**, the I²t command is active and the converter is still enabled.

IMPORTANT

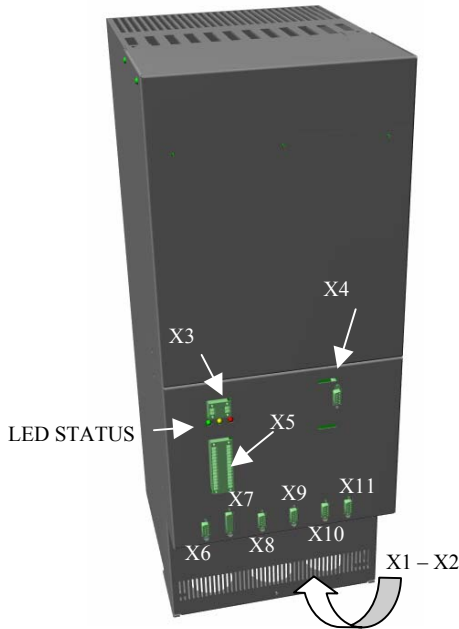

HID75

Terminal											
	X1					X2			Bra. Res.		X2
PE	1	2	3	4	5	1	2	3	1	2	4
	L1	L2	L3	DC+	DC-	U	V	W	BR+	BR-	PE motor

HID100 – HID130

Terminal																	
Fan		X1					X2			Bra. Res.							
Auxiliary fan supply		1	2	3	4	5	1	2	3	1	2						
		L1	L2	L3	DC+	DC-	U	V	W	BR+	BR-						
										<table border="1"> <tr> <th>X1</th> <th>X2</th> </tr> <tr> <td>PE</td> <td>4</td> </tr> <tr> <td></td> <td>PE motor</td> </tr> </table>		X1	X2	PE	4		PE motor
X1	X2																
PE	4																
	PE motor																

X5 : terminal connection

0VQ drive supply	15		1	- SR drive enabling
+24V drive supply	16		2	+ SR drive enabling
	17		3	SC B
	18		4	SC A
	19		5	IN 4
GND (DIGITAL)	20		6	0VA
OUT 1	21		7	MON 2
OUT 0	22		8	MON 1
VCC (DIGITAL)	23		9	0VA
GND IN	24		10	- AX
IN 3	25		11	+ AX
IN 2	26		12	0VA
IN 1	27		13	- REF
IN 0	28		14	+ REF

X6 : "resolver" (DB9 female)	
1	PTC -
2	A GND
3	ECC -
4	SIN -
5	COS -
6	PTC +
7	ECC +
8	SIN +
9	COS +

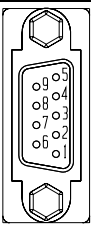

X7 : "sincos" (DB15 female)			
1	PTC -	10	Ve
2	SHIELD	11	SENSE -
3	A GND	12	CLK -
4	SENSE +	13	DATA -
5	CLK +	14	B -
6	DATA +	15	A -
7	B +		
8	A +		
9	PTC +		

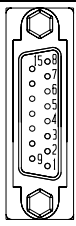

X8 : "RS422/485" (DB9 female)	
1	TX422 +
2	RX422 +
3	TX422 -
4	RX422 -
5	SHIELD
6	Termination
7	N.C.
8	N.C.
9	0V F

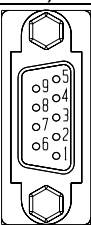

X9 : "encoder input" (DB9 female)	
1	EIN A +
2	EIN A -
3	EIN B +
4	EIN B -
5	EIN C +
6	EIN C -
7	0VF
8	SHIELD
9	+5V F

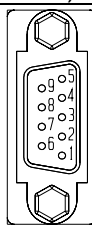

X10 : "encoder output" (DB9 male)	
1	EOUT A +
2	EOUT A -
3	EOUT B +
4	EOUT B -
5	EOUT C +
6	EOUT C -
7	0VF
8	Reserved
9	Reserved

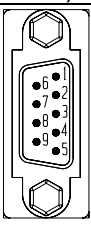

X11 : "CAN" (DB9 male)	
1	N.C.
2	CANL
3	GND CAN
4	Reserved
5	SHIELD
6	Reserved
7	CANH
8	N.C.
9	Reserved

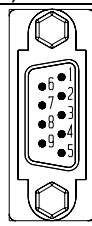

3.4 PE (Protective Earth) connections

Minimize the length of the individual ground wires by placing grounding bar as close as possible to the converters. The grounding bar must be a copper bar and must be installed in contact with the cabinet metal frame. The table shows the minimum dimensions depending on length.

Use only stranded copper wire rated for 75°C minimum.

For the model HID2 up to HID45 use a minimum wire section of 10 mm² for grounding.

For HID75, 100 and 130 connect the ground wire to the PE pin of X1 terminal block with the following cross sections / tightening torque :

Length (m)	Width (mm)	Thickness (mm)
0.5	20	6/8
1	40	6/8
1.5	50	6/8

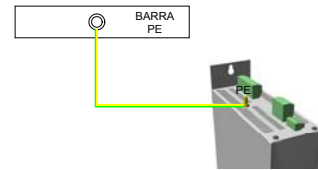

Model	HID75	HID100-HID130
Section	25÷50mm ² (AWG4)	35÷95mm ² (AWG1)
Tight. torque	6 ÷ 8 Nm	42 Nm

3.5 Power stage supply connection

The converter can be used only in grounded TT and TN industrial networks, suitable for use on a circuit capable of delivering not more than 5000 RMS symmetrical amperes, 480V maximum.

Do not use in ungrounded networks or in networks with asymmetrical grounding (IT).

Continuous supply connection

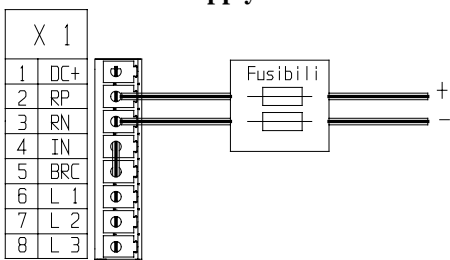

For HID35 and HID45 connect the grounding cable in 9 pin of X1.

per HID75,100 e 130:

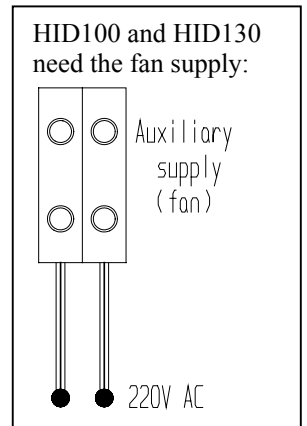
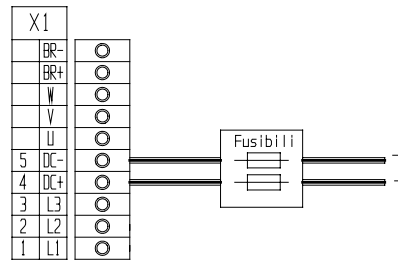

Connection to AC 3-phase network

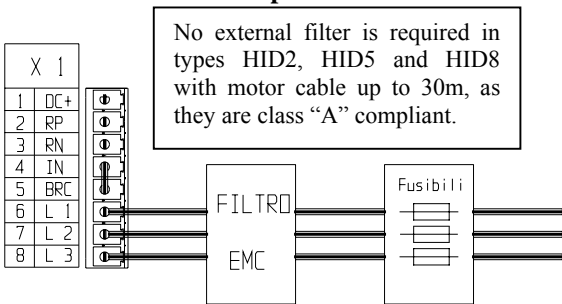

No external filter is required in types HID2, HID5 and HID8 with motor cable up to 30m, as they are class "A" compliant.

Connection to AC 1-phase network

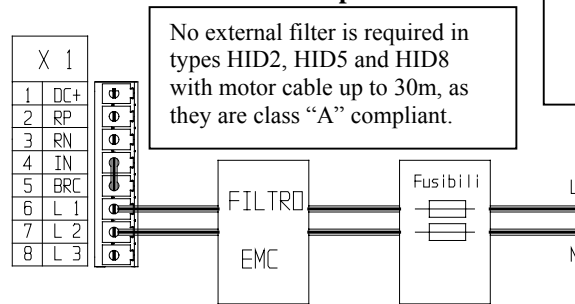

No external filter is required in types HID2, HID5 and HID8 with motor cable up to 30m, as they are class "A" compliant.

For HID35 and HID45 connect the grounding cable in 9

3.6 Motor with emergency brake

Terminal block X3 requires a dedicated 24VDC to terminals 1 and 4. Do not use the same supply of the control stage. Terminals 2 and 3 control the brake through a static relay.

WARNING

Controls the output controlling the emergency brake of terminal block X3 (pin 2 and 3), managed as a command ON/OFF from drive with internal bit (b42.8).

The brake block-release function in all operating conditions must be performed by the user.

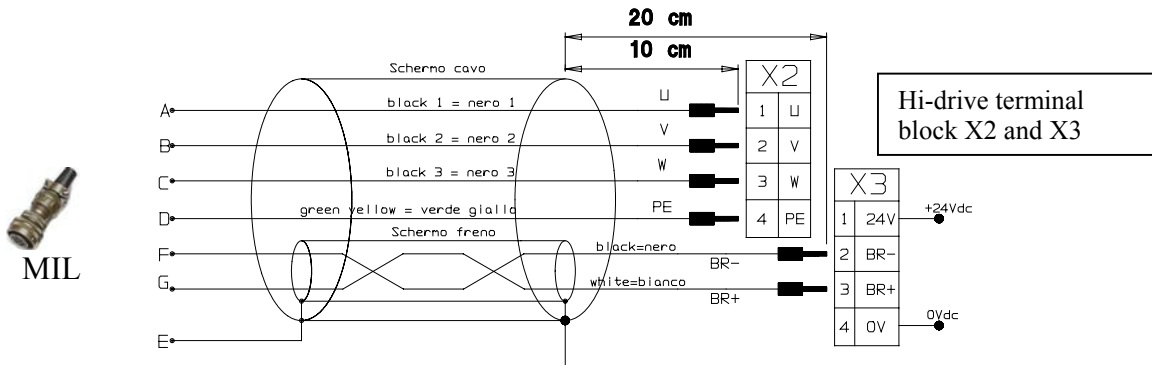

3.7 External braking resistor connection

The converter is equipped with internal braking resistor, except HID75, HID100 and HID130 that have inside the braking transistor only (see “technical data” section).

An external braking resistor can be used if an higher braking power need to be handled.

The external braking resistor must have the same [Ω] value as the internal one. Install a bipolar thermo-magnetic switch (or a fuse pair) between the resistor and the converter (see “dynamic braking” section).

The maximum cable length for the external braking resistor is 3 meters.

For **HID2 ... HID45** models, remove the jumper between terminals IN and BRC (X1 terminal block) and connect the external resistor between terminals RP and BRC.

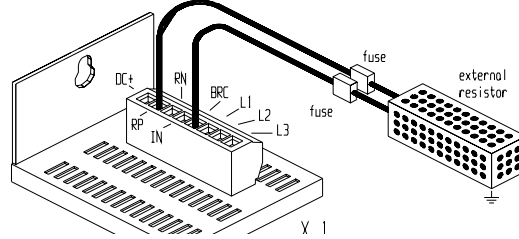
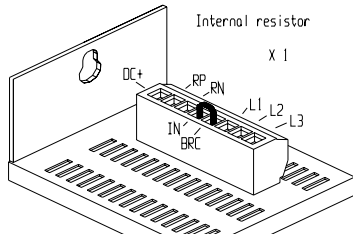

For **HID75, 100 and 130** between +BR and –BR:

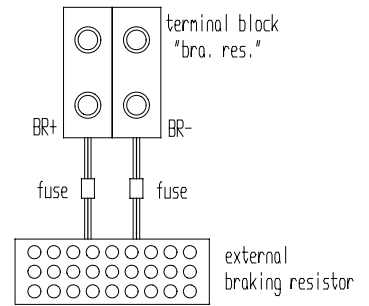

During operation, the external resistor reaches high temperatures. Let the external resistor cool down before performing any operation on it.

3.8 Control stage supply connection



The drive electronics - including powering-up and switch-off operations - is supplied at 24VDC.

The 24V power supply must be exclusively dedicated to the drive power supply. Sharing the power supply with other devices (e.g. brakes, electro valves, etc.) could cause malfunctions.

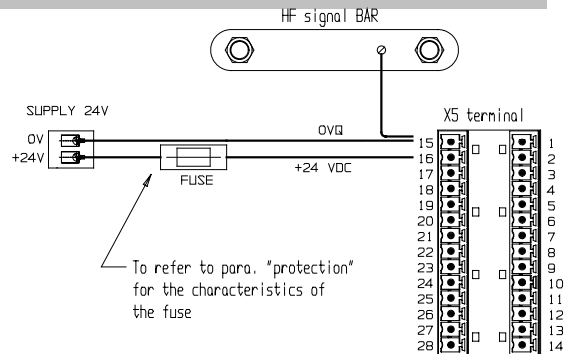

3.9 Analogue and digital I/Os connection

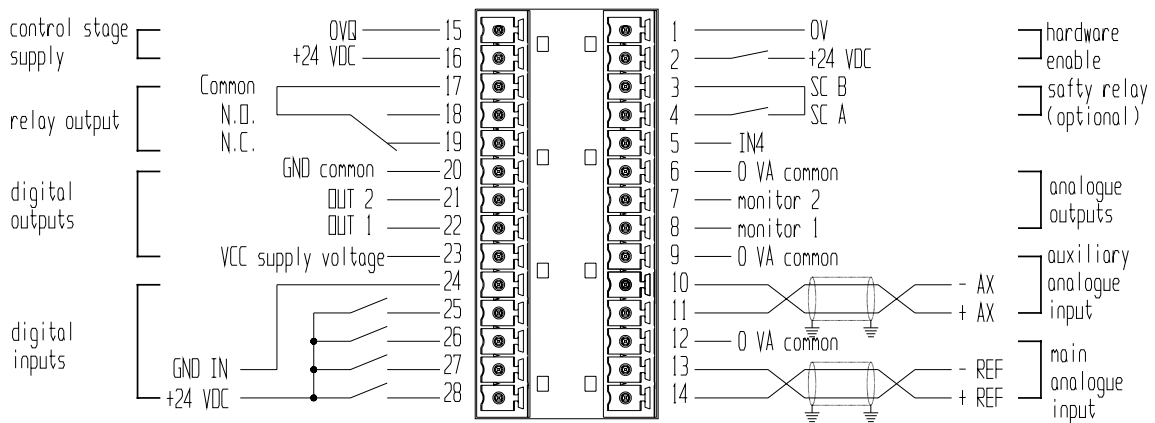

Digital outputs	
Number	2 opto isolate
Type	PNP open collector
External digital power supply	5 ÷ 24Vdc
Rise time	≈200µs
VH	V _{POWER} – 1.0 V
VL	-0.5 ÷ 1.5V
Max. output current	100mA
Short-circuit protection	Yes
Overload protection	Yes

Main analogue input:	
Number	1
Range	±10V differential
Input resistance	8.61kΩ ±5%
Resolution	14 bit + sign
Maximum frequency	2 kHz
Auxiliary analogue input	
Number	1
Range	±10V differential
Input resistance	8.61kΩ ±5%
Resolution	10 bit
Maximum frequency	800 Hz

Analogue outputs	
Number	2
Range	±10V
Output resistance	1kΩ
Resolution	10 bit + sign
Max. output current	1.5mA
Short circuit protection	Yes
Overload protection	Yes

Relay output	
Number	1 (NO - NC)
Voltage	24V
Max current	1A

Digital inputs	
Number	5 opto isolate
High voltage range	15 ÷ 24V
Low voltage range	0 ÷ 9V
Input resistance	20kΩ±5%
Reaction time	≈2.5µs
Type of driving required	PNP

3.10 Resolver

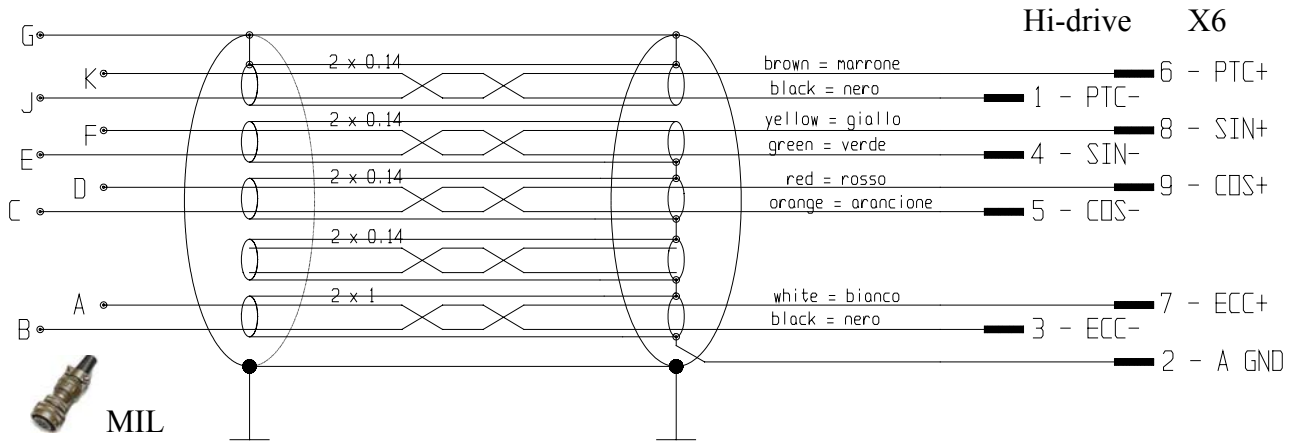

3.11 Sinusoidal encoder + EnDat

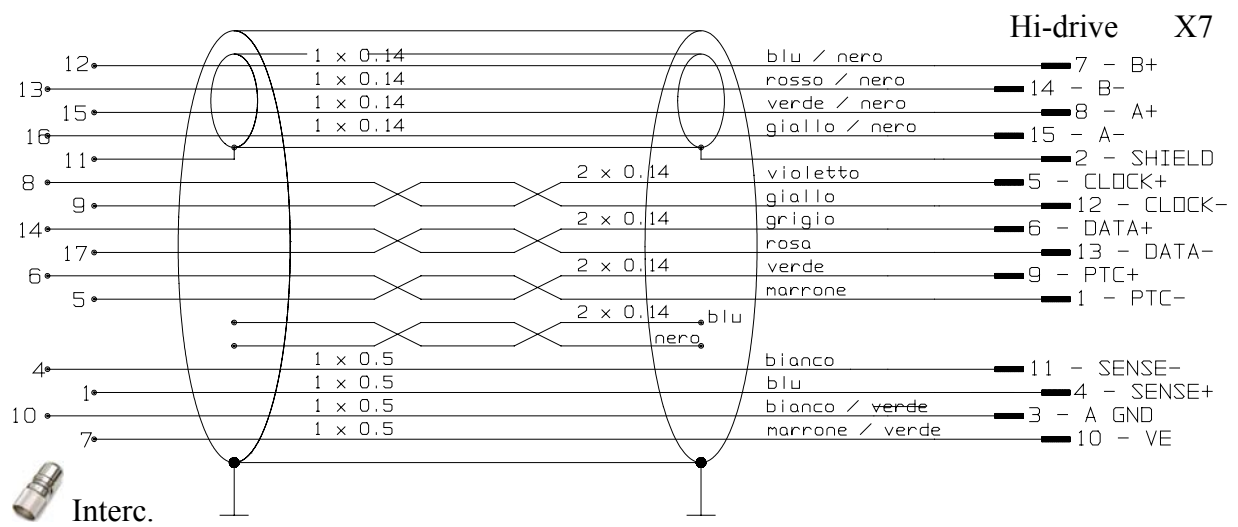

3.12 Sinusoidal encoder + Hiperface

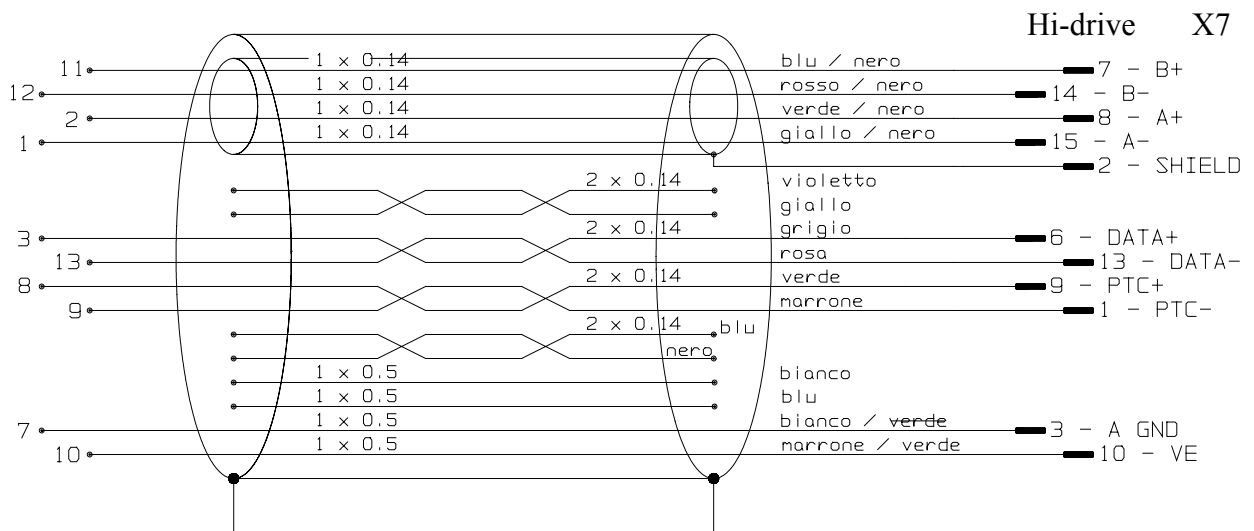

4 START-UP



In Its basic configuration, Hi-drive can control both synchronous permanent magnet motors (brushless) and asynchronous induction motors. The setting of Pr31 can select either of the following: **Pr31=0**, synchronous motor (default setting); **Pr31=1**, asynchronous motor.
The drive is supplied with default factory parameter settings.
See the following chapters for use and start-up.

4.1 Selection of motor type



The first time the converter is powered up, or following a default command, the drive indicates a “Def” condition (alarm Pr23=15).

In order to leave the drive’s initial condition, the operator shall have to input the motor data.

The parameters defining motor types are as follows:

Pr29	Number of motor poles	N.
Pr32	rated motor speed	r.p.m.
Pr33	rated motor current (ex. 2.5A, write 2.5)	A
Pr46	phase-phase motor resistance (ex. 1,8Ω, write 1.8)	ohm
Pr47	phase-phase motor inductance (ex. 2.6mH, write 2.6)	mH
Pr60	number of resolver poles	N.

With asynchronous motors, the values above shall be supplemented with the following parameters:

Pr45	base speed	r.p.m.	} <u>Only asynchronous motors</u>
Pr48	slip	r.p.m.	
Pr49	magnetizing current	A	
Pr32	motor limit speed	r.p.m.	

After setting the parameters that identify the motor, the operator shall enter a data save command, **b42.15** (with drive disabled, b41.5=0). The drive will set the values of parameters Pr2, Pr3, Pr16, Pr17, Pr18 and Pr19 through its internal logic. The automatic calculation of the above listed parameters is performed only of the drive is in the default condition (alarm 15).

4.2 Setting feedback



Mode description				No. of pulses revolution	Input												
Resolver	b65.15=0	b65.14=0	-	-	X6												
SinCos + EnDat	b65.15=0	b65.14=1	Pr62=0	Pr58	X7 <table border="1"> <thead> <tr> <th>V_{dc}</th> <th colspan="2">Encoder power supply</th> </tr> </thead> <tbody> <tr> <td>5</td> <td>b65.7=0</td> <td>b65.6=0</td> </tr> <tr> <td>8</td> <td>b65.7=0</td> <td>b65.6=1</td> </tr> <tr> <td>12</td> <td>b65.7=1</td> <td>b65.6=0</td> </tr> </tbody> </table>	V _{dc}	Encoder power supply		5	b65.7=0	b65.6=0	8	b65.7=0	b65.6=1	12	b65.7=1	b65.6=0
V _{dc}	Encoder power supply																
5	b65.7=0	b65.6=0															
8	b65.7=0	b65.6=1															
12	b65.7=1	b65.6=0															
SinCos	b65.15=0	b65.14=1	Pr62=1														
Less Wiring	b65.15=0	b65.14=1	Pr62=2														
Incremental Encoder	b65.15=0	b65.14=1	Pr62=3														
SinCos + Hiperface	b65.15=0	b65.14=1	Pr62=7														
SinCos (One sin wave per pole pitch)	b65.15=0	b65.14=1	Pr62=8														
Incremental Encoder + Hall sensor	b65.15=0	b65.14=1	Pr62=10														
Incremental Encoder	b65.15=1	b65.14=0	Pr63=3	Pr59	X9												

5 MOTIONWIZ CONFIGURATION TOOL



* The MotionWiz program can be found on the CD rom supplied with the drive or downloaded from our website: www.sbcelettronica.com

6 ALARMS

Pr23	Alarm	Pr23	Alarm	Pr23	Alarm
0	No alarm	6	Power module overtemperature	21	Undervoltage 24VDC
1	Overvoltage	7	External alarm	22	Ambient over temperature
2	Undervoltage	8	Auxiliary alarm	24	Braking transistor protection
3	Overcurrent	10(*)	PLC check sum	25(**)	Speed loop FBK initialization error
4	Speed loop FBK error	11(*)	Parameter check sum	26(**)	Position loop FBK initialization error
5	PTC motor alarm	15	Default parameters	28	Position loop FBK error
(*) reset only after default values have been loaded and saved.				I ² T	Current limit - “the red led is blinking continuously”
(**)can be only reset at the next power on.					



Divisione S.B.C.



Worldwide distribution

EUROPE

BELGIUM, LUXEMBURG PROCOTEC BVBA

Lieven Bauwensstraat 25A
8200 Brugge (Industriezone Waggelwater)
Tel. +32-50-320611 - Fax +32-50-320688
www.procotec.be - info@procotec.be

DENMARK SERVOTECH AS

Ulvhavevej 42-46 - 7100 VEJLE
Tel. +45-7942-8080 - Fax. +45-7942-8081
www.servotech.dk - servotech@servotech.dk

FRANCE TRANSTECHNIK SERVOMECHANISMES S.A.

Z.A. Ahuy Suzon
17 Rue Des Grandes Varennes - 21121 Ahuy
Tel. +33-380-550000 - Fax +33-380-539363
www.transtechnik.fr - infos@transtechnik.fr

GREAT BRITAIN AMIR POWER TRANSMISSION LTD

Amir House, Maxted Road - Hemel Hempstead
Hertfordshire - HP2 7DX
Tel +44-1442-212671 - Fax +44-1442-246640
www.amirpower.co.uk - apt@amirpower.co.uk

QUIN SYSTEMS LIMITED

Oakland Business Centre
Oakland Park - Wokingham
Berkshire - RG41 2FD - U.K.
Tel. +44-118-9771077 - Fax +44-118-9776728
www.quin.co.uk - sales@quin.co.uk

HOLLAND VARIODRIVE AANDRIJF-EN BESTURINGSTECHNIEK B.V.

A. van Leeuwenhoekstraat 22
3261 LT Oud-Beijerland
Tel. +31-186-622301 - Fax +31-186-615228
www.variodrive.nl - sales@variodrive.nl

PORTUGAL

SIEPI LDA
Parque Industrial do Arneiro, Lote 46
São Julião do Tojal - 2660-456 Loures
Tel. +351-21-9737330 - Fax +351-21-9737339
www.gruposiepi.com - Siepi@mail.Telepac.Pt

SPAIN

INTRA AUTOMATION SL
C/ALABAU, 20 Horno Alcedo
E-46026 Valencia
Tel. +34-96-3961008 - Fax +34-96-3961018
www.intraautomationsl.com
info@intraautomationsl.com

SWITZERLAND INDUR ANTRIEBSTECHNIK AG

Margarethenstrasse 87
CH - 4008 Basel
Tel. +41-61-2792900 - Fax +41-61-2792910
www.indur.ch - info@indur.ch

TURKEY

SANPA LTD STI
Plaj Yolu, Ersoy Apt. No. 14 D, 4
34740 Suadiye - Istanbul
Tel. +90-216-4632520 - Fax +90-216-3622727
www.sanpaltd.com.tr - sanpa@turk.net

NORTH AMERICA

CANADA PARS ROBOTICS GROUP INC.

441 Esna Park Drive, units 11-12
Markham, Ontario, L3R 1H7
Tel. +1-905-4772886 - Fax +1-905-4770980
www.parsrobotics.com - pars@parsrobotics.com

UNITED STATES PARKER HANNIFIN CORPORATION COMPUMOTOR DIVISION

5500 Business Park Drive
Rohnert Park, CA 94928
Tel. +1-707-5847558 - Fax +1-707-5842446
www.compumotor.com
CMR_Customer_Service@parker.com

CENTRAL AMERICA

MEXICO PARKER HANNIFIN DE MÉXICO

Eje 1 Norte No. 100
Parque Ind. Toluca 2000 - Toluca 50100
Tel. +52 722 - 2754200 - Fax +52 722 - 2799308
www.parker.com

SOUTH AMERICA

ARGENTINA, CILE, PARAGUAY, URUGUAY R.A. INGENIERIA ELECTRONIC IND. Y COM.

Arregui 5382 - 1408 Buenos Aires
Tel. +54-11-45675543 - Fax +54-11-45662870
www.raing.com.ar - ra@raing.com.ar

BRAZIL

AUTOMOTION LTDA.
Acesso Jose Sartorelli Km2,1
Parque das Arvores, 18550-000 Boituva - SP
Tel. +55 15 33639900 - Fax +55 15 33639911
www.automotion.com.br - coml@automotion.com.br

VENEZUELA TEKNOMAQ C.A.

Avenida Manuel Diaz Rodriguez
Edif. Milano Local C
Santa Monica - Caracas
Tel. +58-212-6335657 - Fax +58-212-6330466
teknomaq@cantv.net

ASIA

ISRAEL AF ELECTRONICS MOTOR CONTROL

PO BOX 741
52322 Ramat-Gan Israel
Tel. +972-3-6745457 - Fax +972-3-6776342
afmotor@zahav.net.il

MALAYSIA PRESTIGE MACHINERY

No. 46, Jalan Bateri 34/5
Bukit Kemuning Light Industrial Area
42450 Shah Alam - Sengalor D.E.
Tel. +60-3-5880-9851 - Fax +60-3-5880-8364
presmach@maxis.net.my

TAIWAN AUTO ACCURACY CO. LTD

No. 18, 35RD, Taichung Industrial Park
Taichung City
Tel. +886-42-3594847 - Fax +886-42-3591083
www.autoaccuracy.com.tw - autoauto@ms2.hinet.net

OCEANIA

AUSTRALIA, NEW ZEALAND MOTION SOLUTIONS AUSTRALIA PTY LTD

Factory 2, 21-29 Railway Avenue
Huntingdale, 3166
Melbourne, Victoria
Tel. +613-9563-0115 - Fax +613-9568-4667
www.motion-solutions.com.au
sales@motion-solutions.com.au



Parker Hannifin S.p.A.
Electromechanical Automation
Via Gounod 1
20092 Cinisello Balsamo (MI), Italia
Tel: +39 0266012459
Fax: +39 0266012808
www.sbcelettronica.com
sales.sbc@parker.com

Parker Hannifin GmbH
Electromechanical Automation
Robert-Bosch-Str. 22
D-77656 Offenburg, Germania
Tel: +49 (0)781 509-0
Fax: +49 (0)781 509-98-258
www.parker-emd.com
sales.hauser@parker.com

Parker Hannifin plc
Electromechanical Automation
21 Balena Close
Poole, Dorset. BH17 7DX UK
Tel: +44 (0)1202 50 6200
Fax: +44 (0)1202 69 5750
www.parker-emd.com
sales.digiplan@parker.com